



# MODEL G0656X 8" JOINTER w/SPIRAL CUTTERHEAD MANUAL INSERT

The Model G0656X is the same machine as the Model G0656, except it has a spiral cutterhead. Besides the differences noted in this insert, all other content in the Model G0656 owner's manual applies to this machine. Before operating your new machine, you **MUST** read and understand this insert and the entire Model G0656 manual to reduce the risk of injury when using this machine.

If you have any further questions about this manual insert or the differences between the Model G0656X and the Model G0656, contact our Technical Support at (570) 546-9663 or email [techsupport@grizzly.com](mailto:techsupport@grizzly.com).

## Machine Inventory

Refer to the inventory photos in the G0656 Manual on **Page 11**. After all the parts have been removed from the crate, you should have the following items:

<b>Wood Crate:</b>	<b>Qty</b>
<b>A.</b> Jointer Assembly .....	1
<b>B.</b> Cutterhead Guard.....	1
<b>C.</b> Handwheels.....	2
<b>D.</b> Handles .....	2
<b>E.</b> Fence Tilt Lever .....	1
<b>F.</b> Push Blocks.....	2
<b>G.</b> Spiral Cutterhead Hardware (Not Shown)	
—Inserts 14 x 14 x 2.....	5
—Flat Head Torx Screws T20 M6-1 x 15 10	
—L-Wrench Torx T20.....	1
—Driver Bit Torx T20 .....	1
<b>H.</b> Tool Hardware Bag	
—Hex Wrenches 2.5, 3, 4, 6mm .....	1 Ea
—Open-End Wrench 8/10, 12/14mm.....	1Ea

The Model G0656X Cardboard Box and Assembly Fastener Components are identical to the corresponding components listed on **Page 11** of the G0656 Manual.

## Setting Outfeed Table Height

The outfeed table height **MUST** be level with the carbide inserts when they are at top-dead-center. If the outfeed table is set too low, the workpiece will be tapered from front to back. If the outfeed table is set too high, the workpiece will hit the edge of the outfeed table during operation, increasing the chance of kickback.

### To set the outfeed table height:

1. DISCONNECT JOINTER FROM POWER!
2. Move the cutterhead guard out of the way or remove it, and open the rear access panel.
3. Place a straightedge on the outfeed table so it extends over the cutterhead and rotate the cutterhead pulley until one of the carbide inserts is at top-dead-center (TDC), as shown in **Figure 1**.

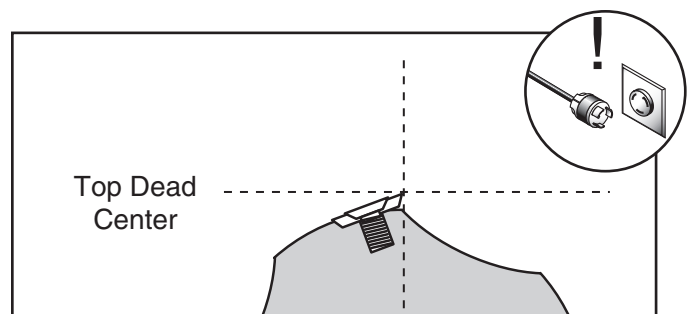

**Figure 1.** Cutterhead insert at top-dead-center.

- When correctly set, the carbide insert will just touch the straightedge when the insert is at its highest point of rotation (**Figure 2**).

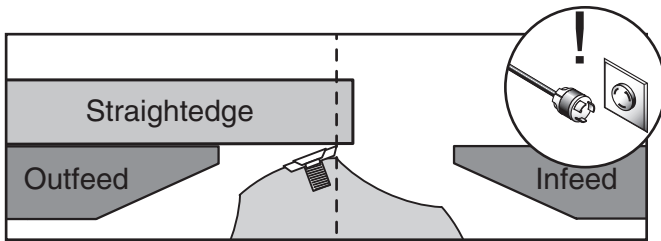

**Figure 2.** Using a straightedge to align the outfeed table height with insert at TDC.

—If your outfeed table is correctly set, no adjustments are necessary.

—If the insert lifts the straightedge off the table or the insert is below the straightedge, loosen the outfeed table lock and adjust the outfeed table height with the handwheel until the straightedge just touches an insert at its highest point of rotation.

**Tip:** Some advanced woodworkers have found that they can virtually eliminate snipe by setting the outfeed table in the following manner: Repeat **Steps 1-4** using a freshly exposed insert. Place two pencil marks on the straightedge  $\frac{5}{32}$ " apart, and place the outward mark on the edge of the outfeed table, as shown in **Figure 3**.

Lower the outfeed table slightly so the insert lifts the straightedge off the table. Rotate the cutterhead clockwise—the straightedge should move  $\frac{5}{32}$ " toward the infeed table and the inward mark should be directly over the edge of the outfeed table, as shown in **Figure 4**. Continue adjusting the outfeed table until the cutterhead moves the straightedge  $\frac{5}{32}$ " toward the infeed table.

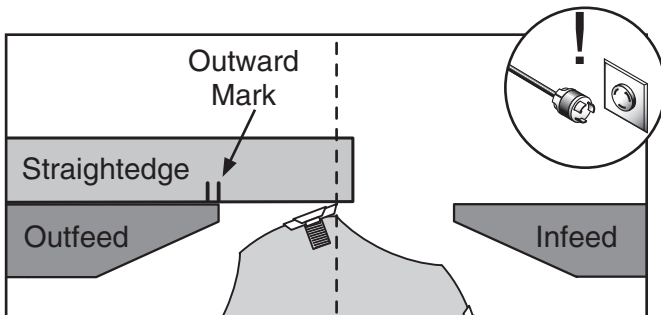

**Figure 3.** Straightedge outward mark at edge of outfeed table.

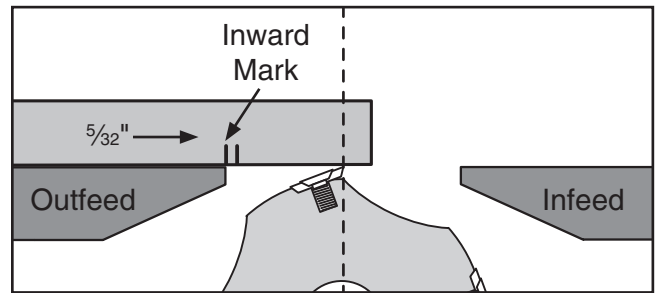

**Figure 4.** Straightedge inward mark at edge of outfeed table.

- Lock the outfeed table, reinstall the cutterhead guard, and close the rear access panel.

## Replacing Carbide Inserts

### Tools Needed:

**Qty**

L-Wrench Torx w/T20 Torx Driver..... 1

The cutterhead is equipped with 40 indexable carbide inserts. Each insert can be rotated to reveal any one of its four cutting edges. Therefore, if one cutting edge becomes dull or damaged, simply rotate it 90° to reveal a fresh cutting edge (**Figure 5**).

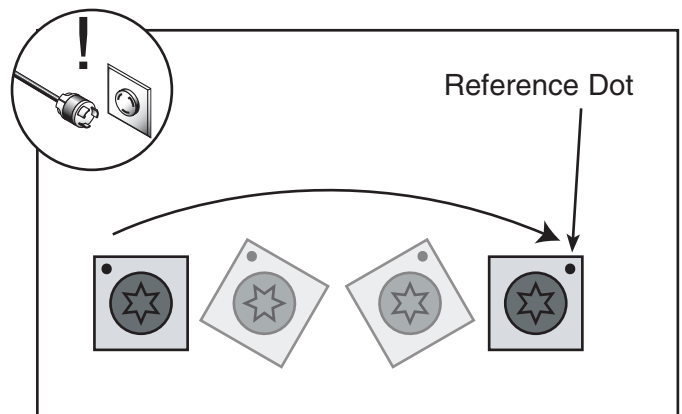

**Figure 5.** Insert rotating sequence.

In addition, each insert has a reference dot on one corner. As the insert is rotated, the reference dot location can be used as an indicator of which edges are used and which are new. When the reference dot revolves back around to its starting position, the insert should be replaced.

Replacement carbide inserts should be included with the cutterhead. If you need additional inserts, call Grizzly Customer Service at (800) 523-4777 and order Part P0452Z002, Replacement Carbide Insert 14x14x2mm.



**To rotate or change a carbide insert:**

1. DISCONNECT JOINTER FROM POWER!
2. Move the cutterhead guard out of the way, or remove it.
3. Remove any sawdust from the head of the carbide insert Torx screw.
4. Remove the Torx screw and carbide insert.
5. Clean all dust and dirt off of the insert and the cutterhead pocket from which the insert was removed, and replace the insert so a fresh, sharp edge is facing outward. Make sure the insert is seated in the pocket on the cutterhead.

**Note:** *Proper cleaning is critical to achieving a smooth finish. Dirt or dust trapped between the insert and cutterhead will slightly raise the insert, and make noticeable marks on your workpieces the next time you cut.*

6. Lubricate the Torx screw threads with a light machine oil, wipe the excess oil off the threads, and torque the Torx screw to 48-50 inch/pounds.

**Note:** *Excess oil may squeeze between the insert and cutterhead or at the bottom of the screw hole, causing hydrostatic lock and preventing the screw from fully tightening, thereby lifting the insert or screw slightly and affecting workpiece finishes. Make sure to carefully clean off any excess oil to prevent this from happening.*





# MACHINE DATA SHEET

Customer Service #: (570) 546-9663 • To Order Call: (800) 523-4777 • Fax #: (800) 438-5901

## MODEL G0656X 8" JOINTER w/SPIRAL CUTTERHEAD & MOBILE BASE

### Product Dimensions:

Weight ..... 465 lbs.  
Length/Width/Height ..... 72½" x 26" x 47¼"  
Foot Print (Length/Width)..... 26¾" x 16½"

### Shipping Dimensions:

#### Box #1

Type..... Wood Crate  
Content..... Machine  
Weight ..... 435 lbs.  
Length/Width/Height ..... 25" x 81" x 15"

#### Box #2

Type..... Cardboard  
Content..... Stand  
Weight ..... 167 lbs.  
Length/Width/Height ..... 19" x 30" x 27"

### Electrical:

Switch..... ON/OFF Push Button with Large OFF Paddle  
Switch Voltage ..... 220V  
Cord Length ..... 6 ft.  
Cord Gauge ..... 14 gauge  
Minimum Circuit Size ..... 20A  
Included Plug ..... No  
Recommended Plug Type ..... 6-20

### Motors:

#### Main

Type..... TEFC Capacitor Start Induction  
Horsepower ..... 3 HP  
Voltage ..... 220V  
Phase ..... Single  
Amps ..... 15A  
Speed ..... 3450 RPM  
Cycle..... 60 Hz  
Number Of Speeds..... 1  
Power Transfer..... V-Belt Drive  
Bearings ..... Shielded and Lubricated

### Main Specifications:

#### Operation Information

Fence Length ..... 34⅞"  
Fence Width ..... 1¼"  
Fence Height..... 5"  
Fence Stops ..... 45, 90, and 135 deg.





**Cutting Capacities**

Bevel Jointing .....	Left & Right 45 deg.
Maximum Width of Cut.....	8"
Maximum Depth of Cut .....	1/8"
Maximum Rabbeting Depth.....	1/2"
Number of Cuts Per Minute.....	21,400

**Cutterhead Information**

Cutterhead Type.....	Spiral
Cutterhead Diameter .....	3"
Number of Cutter Spirals.....	4
Number of Indexable Cutters .....	40
Cutter Insert Type.....	Indexable Carbide
Cutter Insert Length.....	14mm
Cutter Insert Width .....	14mm
Cutter Insert Thickness .....	2mm
Cutterhead Speed .....	5350 RPM

**Table Information**

Table Length .....	72 1/2"
Table Width .....	9"
Floor to Table Height.....	33 1/2"
Table Adjustment Type .....	Handwheels

**Construction**

Body Assembly Construction .....	Cast Iron
Stand Construction.....	One-Piece Steel Cabinet
Fence Assembly Construction.....	Cast Iron
Guard Construction .....	Die Cast Metal
Dovetailed Ways on Bed.....	Adjustable
Parallelogram .....	No

**Other Information**

Number of Dust Ports .....	1
Dust Port Size .....	4"
Mobile Base.....	Built-In

**Other Specifications:**

Country Of Origin.....	China
Warranty.....	1 Year
Serial Number Location .....	ID Label on Front of Stand
Assembly Time .....	1 Hour

**Features:**

- Built in Easy-to-Use Mobile Base
- Included Push Blocks
- Top Mount Switch Controls
- Super Long 72 1/2" Bed
- Handwheel Controlled Fence Adjustment
- Rabbeting Table



# Table Parts Breakdown

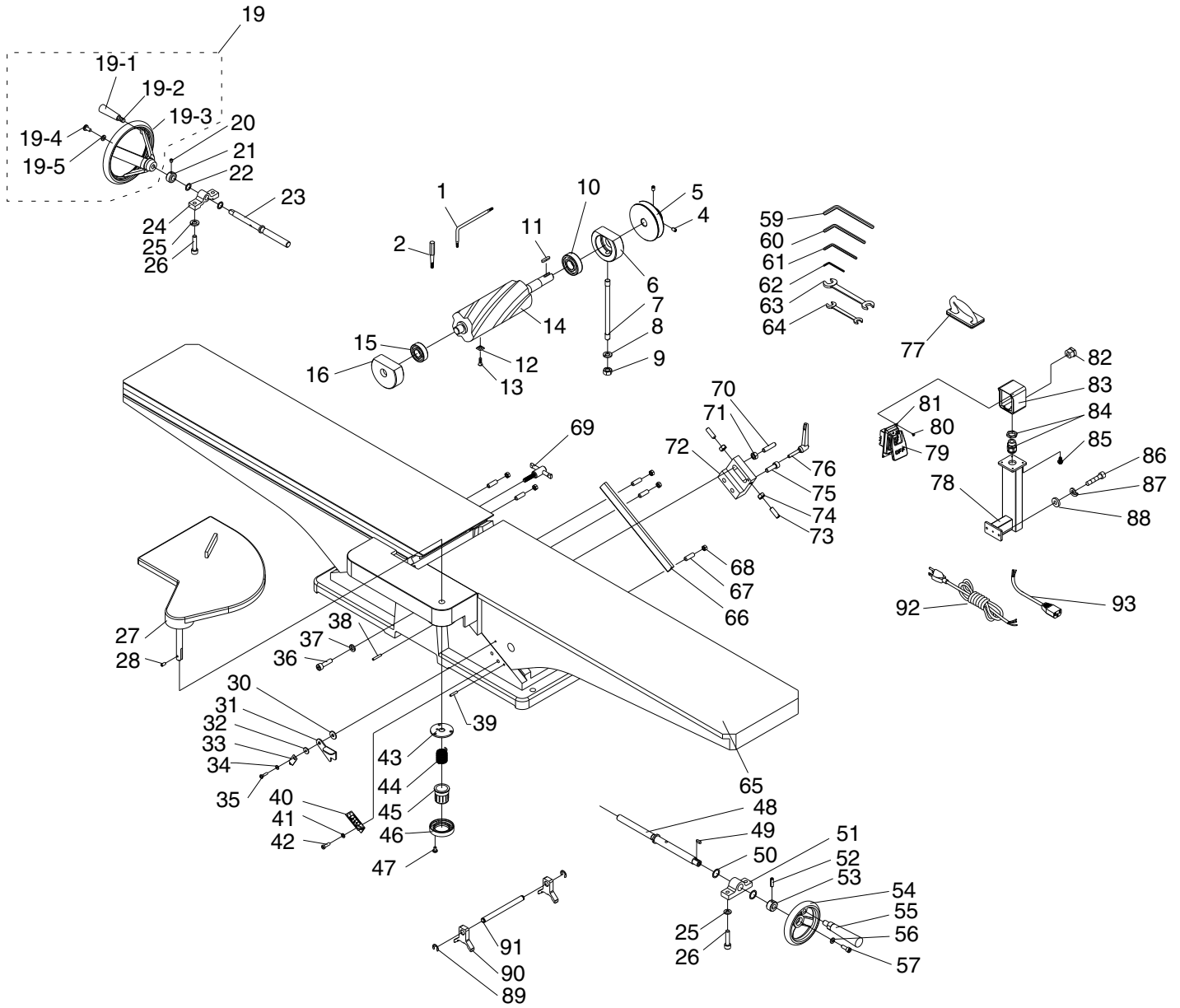

# Table Parts List

REF	PART #	DESCRIPTION
1	P0452Z009	L-WRENCH TORX T20
2	P0452Z001	DRIVER BIT TORX T20
4	PSS01M	SET SCREW M6-1 X 10
5	P0656005	PULLEY
6	P0656006	RIGHT BEARING SUPPORT BLOCK
7	P0656007	STUD
8	PLW06M	LOCK WASHER 10MM
9	PN02M	HEX NUT M10-1.5
10	P6204	BALL BEARING 6204ZZ
11	PK74M	KEY 6 X 6 X 35
12	P0452Z002	INDEXABLE INSERT 14 x 14 x 2
13	PFH35M	FLAT HD TORX SCR T20 M6-1 X 15
14	P0490X062	SPIRAL CUTTERHEAD 8"
15	P6203	BALL BEARING 6203ZZ
16	P0656016	LEFT BEARING SUPPORT BLOCK
19	P0656019	HANDWHEEL ASSY
19-1	P0656019-1	HANDLE
19-2	P0656019-2	SHOULDER SCREW
19-3	P0656019-3	HANDWHEEL
19-4	PSB26M	CAP SCREW M6-1 X 12
19-5	PW03M	FLAT WASHER 6MM
20	PSS02M	SET SCREW M6-1 X 6
21	P0656021	COLLAR
22	P0656022	SPECIAL FLAT WASHER
23	P0656023	SCREW SHAFT
24	P0656024	BLOCK
25	PLW04M	LOCK WASHER 8MM
26	PSB40M	CAP SCREW M8-1.25 X 35
27	P0656027	CUTTERHEAD GUARD
28	PSS53M	SET SCREW M5-.8 X 12
30	P0656030	SPACER
31	P0656031	STOP LEVER
32	PW05M	FLAT WASHER 4MM
33	P0656033	POINTER
34	PW05M	FLAT WASHER 4MM
35	PS21M	PHLP HD SCR M4-.7 X 15
36	PSB40M	CAP SCREW M8-1.25 X 35
37	PLW04M	LOCK WASHER 8MM
38	PRP56M	ROLL PIN 4 X 25
39	P0656039	ALIGNMENT PIN 4 X 20
40	P0656040	DEPTH SCALE
41	PLW01M	LOCK WASHER 5MM
42	PSB24M	CAP SCREW M5-.8 X 16
43	P0656043	PLATE
44	P0656044	TORSION SPRING
45	P0656045	CUP
46	P0656046	RETAINER

REF	PART #	DESCRIPTION
47	PSB53M	CAP SCREW M5-.8 X 18
48	P0656048	SCREW SHAFT
49	PK69M	KEY 4 X 4 X 12
50	P0656050	SPACER
51	P0656051	BLOCK
52	PRP49M	ROLL PIN 5 X 25
53	P0656053	COLLAR
54	P0656054	HANDWHEEL
55	P0656055	HANDLE
56	P0656056	SPECIAL FLAT WASHER
57	PSB26M	CAP SCREW M6-1 X 12
59	PAW06M	HEX WRENCH 6MM
60	PAW04M	HEX WRENCH 4MM
61	PAW03M	HEX WRENCH 3MM
62	PAW02.5M	HEX WRENCH 2.5MM
63	PWR1214	WRENCH 12 X 14
64	PWR810	WRENCH 8 X 10
65	P0656065	TABLE ASSY
66	P0656066	GIB
67	PSS12M	SET SCREW M6-1 X 25
68	PN01M	HEX NUT M6-1
69	P0656069	OUTFEED TABLE LOCK M6-1 X 25
70	P0656070	SPECIAL SCREW
71	PN01M	HEX NUT M6-1
72	P0656072	STOP BLOCK
73	PSS21M	SET SCREW M8-1.25 X 25
74	PN03M	HEX NUT M8-1.25
75	PSB31M	CAP SCREW M8-1.25 X 25
76	P0656076	INFEED LOCK LEVER M6-1 X 30
77	P0656077	JOINTER PUSH BLOCK
78	P0656078	SWITCH PEDESTAL
79	P0656079	SWITCH PADDLE
80	PSB18M	CAP SCREW M4-.7 X 8
81	P0656081	SWITCH BRACKET
82	P0656082	STRAIN RELIEF
83	P0656083	SWITCH BOX
84	P0656084	STRAIN RELIEF
85	PFB17M	FLANGE BOLT M6-1 X 16
86	PSB31M	CAP SCREW M8-1.25 X 25
87	PLW04M	LOCK WASHER 8MM
88	PW01M	FLAT WASHER 8MM
89	PEC015M	E-CLIP 8MM
90	P0656090	KNIFE GAUGE BLOCK
91	P0656091	KNIFE GAUGE ROD
92	P0656092	POWER CORD 14AWG X 3C
93	P0656093	SWITCH CORD 14AWG X 3C



# Fence Parts Breakdown

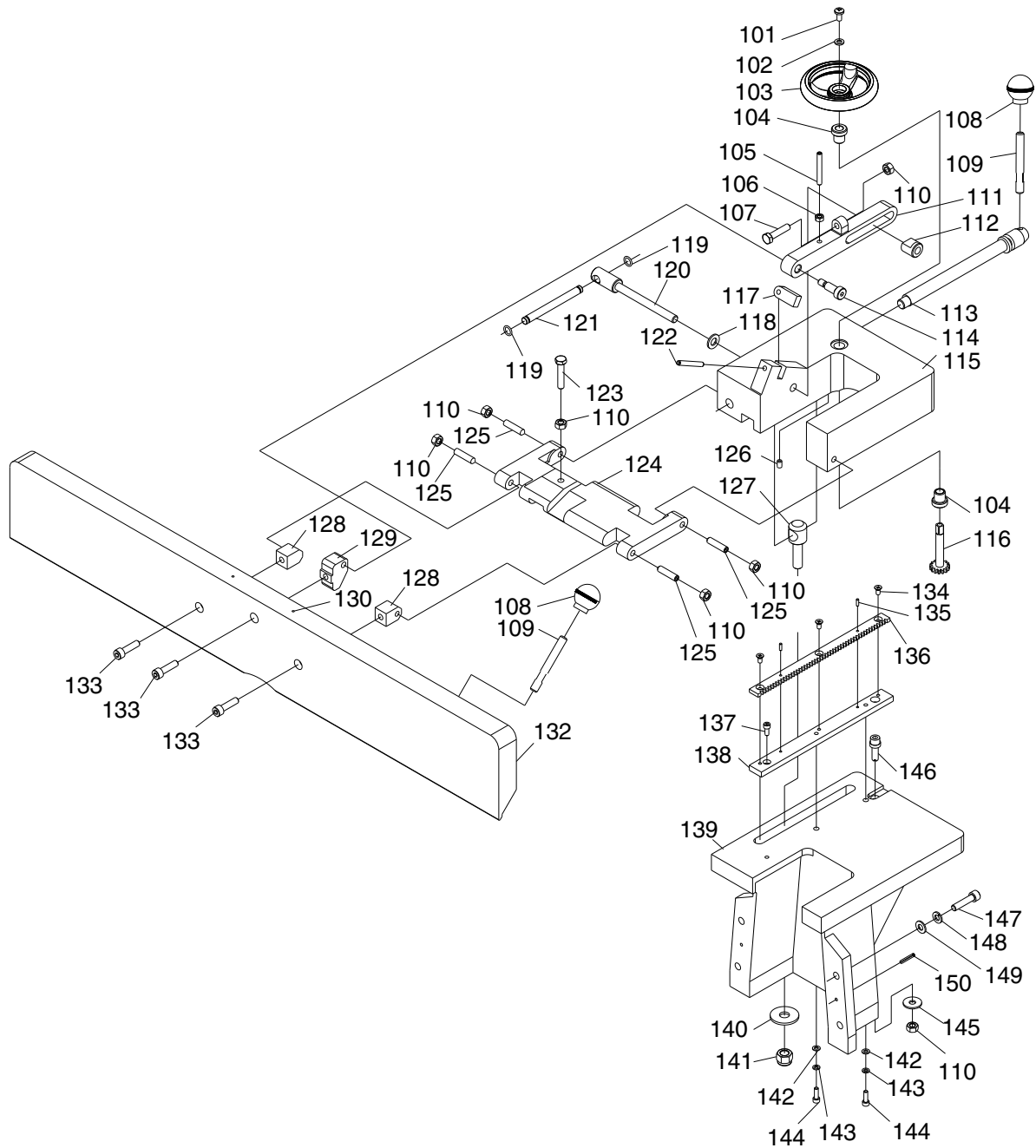

# Fence Parts List

REF	PART #	DESCRIPTION
101	PS14M	PHLP HD SCR M6-1 X 12
102	PW03M	FLAT WASHER 6MM
103	P0656103	HANDWHEEL
104	P0656104	BUSHING
105	PSS85M	SET SCREW M6-1 X 45
106	PN01M	HEX NUT M6-1
107	PB20M	HEX BOLT M8-1.25 X 35
108	P0656108	KNOB M10-1.5
109	P0656109	STUD M10-1.5
110	PN03M	HEX NUT M8-1.25
111	P0656111	CLAMP ARM
112	P0656112	LOCK NUT
113	P0656113	ECCENTRIC LOCK LEVER
114	P0656114	SPECIAL SCREW M10-1.5 X 20
115	P0656115	FENCE CARRIAGE
116	P0656116	GEAR
117	P0656117	90 DEG STOP BLOCK
118	PW04M	FLAT WASHER 10MM
119	POR0010	O-RING 10 X 2
120	P0656120	TILT LOCK SHAFT
121	P0656121	TILT LOCK HANDLE
122	P0656122	ALIGNMENT PIN 6 X 50
123	PB15M	HEX BOLT M8-1.25 X 40
124	P0656124	BRACKET
125	PSS74M	SET SCREW M8-1.25 X 35

REF	PART #	DESCRIPTION
126	PSS01M	SET SCREW M6-1 X 10
127	P0656127	ADJUST LEVER
128	P0656128	SMALL BRACKET BLOCK
129	P0656129	BRACKET BLOCK
130	P0656130	RIVET 2 X 4
132	P0656132	FENCE
133	PSB13M	CAP SCREW M8-1.25 X 30
134	PFH07M	FLAT HD SCR M5-.8 X 10
135	PRP44M	ROLL PIN 3 X 10
136	P0656136	RACK
137	PSB20M	CAP SCREW M5-.8 X 14
138	P0656138	GIB
139	P0656139	FENCE SUPPORT
140	PW06M	FLAT WASHER 12MM
141	P0656141	SPECIAL HEX NUT M12-1.75
142	PW02M	FLAT WASHER 5MM
143	PLW01M	LOCK WASHER 5MM
144	PSB53M	CAP SCREW M5-.8 X 18
145	P0656145	SPECIAL FLAT WASHER
146	P0656146	ECCENTRIC STUD
147	PSB40M	CAP SCREW M8-1.25 X 35
148	PLW04M	LOCK WASHER 8MM
149	PW01M	FLAT WASHER 8MM
150	PRP49M	ROLL PIN 5 X 25



# Stand Parts Breakdown

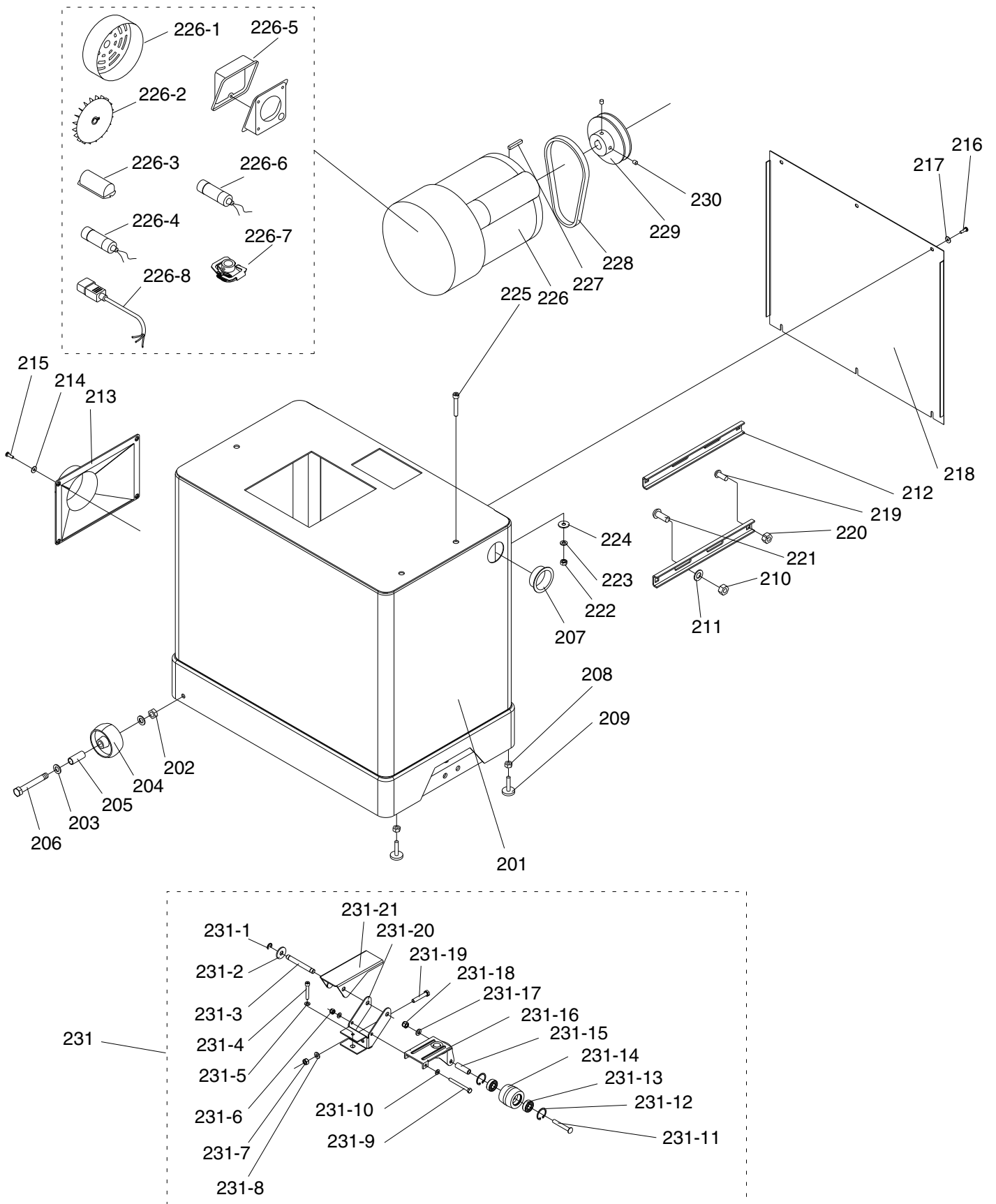

# Stand Parts List

REF	PART #	DESCRIPTION
201	P0656201	CABINET
202	PLN04M	LOCK NUT M8-1.25
203	PW01M	FLAT WASHER 8MM
204	P0656204	WHEEL
205	P0656205	SLEEVE
206	PB86M	HEX BOLT M8-1.25 X 65
207	P0656207	PLASTIC GROMMET
208	PN08	HEX NUT 3/8-16
209	P0656209	ADJUSTING FOOT
210	PN02	HEX NUT 5/16-18
211	PW07	FLAT WASHER 5/16
212	P0656212	MOTOR BRACKET
213	P0656213	DUST PORT
214	PW02M	FLAT WASHER 5MM
215	PS40M	PHLP HD SCR M5-.8 X 16
216	PS40M	PHLP HD SCR M5-.8 X 16
217	PW02M	FLAT WASHER 5MM
218	P0656218	CABINET REAR COVER
219	PCB05	CARRIAGE BOLT 5/16-18 X 3/4
220	PN02	HEX NUT 5/16-18
221	PCB11	CARRIAGE BOLT 5/16-18 X 1
222	PN03M	HEX NUT M8-1.25
223	PLW04M	LOCK WASHER 8MM
224	PW01M	FLAT WASHER 8MM
225	PSB05M	CAP SCREW M8-1.25 X 50
226	P0656226	MOTOR 3PH 220V
226-1	P0656226-1	FAN COVER
226-2	P0656226-2	FAN
226-3	P0656226-3	R CAPACITOR COVER
226-4	P0656226-4	R CAP 30M 450V 2-3/4 X 1-1/2

REF	PART #	DESCRIPTION
226-5	P0656226-5	JUNCTION BOX
226-6	P0656226-6	S CAPACITOR 200M 250V 3-1/2 X 1-1/2
226-7	P0656226-7	CENTRIFUGAL SWITCH
226-8	P0656226-8	MOTOR CORD 14AWG X 3C
227	PK12M	KEY 5 X 5 X 30
228	PVA50	V-BELT A-50 4L500
229	P0656229	MOTOR PULLEY
230	PSS01M	SET SCREW M6-1 X 10
231	P0656231	PEDAL ASSEMBLY
231-1	PR16M	EXT RETAINING RING 9MM
231-2	P0656231-2	SPECIAL FLAT WASHER 9MM
231-3	P0656231-3	SHAFT
231-4	PB22M	HEX BOLT M8-1.25 X 50
231-5	PW01M	FLAT WASHER 8MM
231-6	P0656231-6	SPECIAL HEX NUT M8-1.25
231-7	PN02M	HEX NUT M10-1.5
231-8	PW04M	FLAT WASHER 10MM
231-9	PB45M	HEX BOLT M8-1.25 X 100
231-10	PW01M	FLAT WASHER 8MM
231-11	P0656231-11	SPECIAL BOLT
231-12	PR21M	INT RETAINING RING 35MM
231-13	P6202	BALL BEARING 6202ZZ
231-14	P0656231-14	TROLLEY WHEEL
231-15	P0656231-15	SLEEVE
231-16	P0656231-16	UNIVERSAL KIT TROLLEY
231-17	PW04M	FLAT WASHER 10MM
231-18	P0656231-18	SPECIAL HEX NUT M10
231-19	PB144M	HEX BOLT M10-1.5 X 55
231-20	P0656231-20	BRACKET
231-21	P0656231-21	PEDAL





# Label Placement

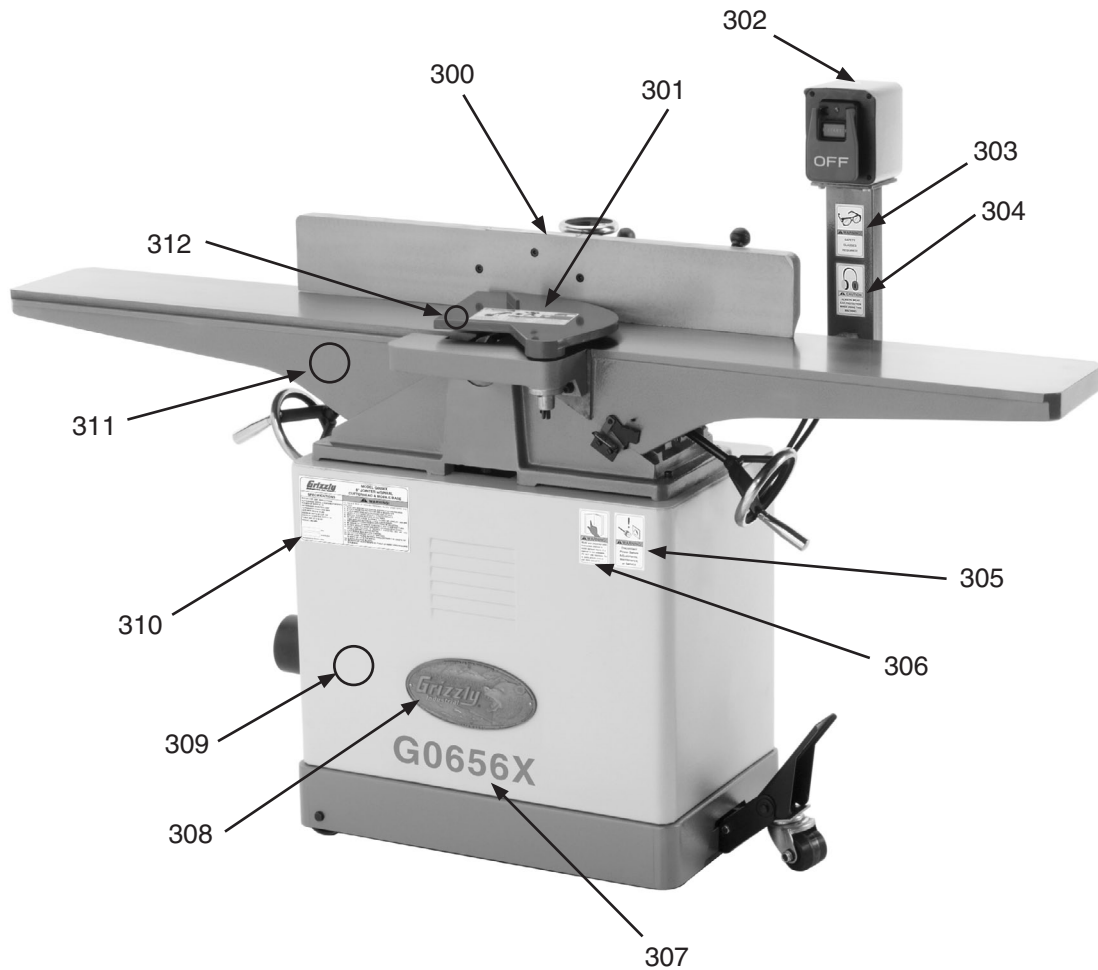

REF	PART #	DESCRIPTION
300	P0656300	FENCE/CUTTERHEAD LABEL
301	P0656301	CUTTTERHEAD GUARD LABEL
302	PLABEL-14	ELECTRICITY LABEL
303	PLABEL-11	SAFETY GLASSES 2" X 3 5/16"
304	PLABEL-15	EAR PROTECTION 2" X 3-5/16"H
305	PLABEL-63	UNPLUG 220V POWER LABEL
306	PLABEL-12A	READ MANUAL-VERTICAL NS 7/05

REF	PART #	DESCRIPTION
307	P0656X307	MODEL NUMBER LABEL
308	G8588	SMALL GRIZZLY NAMEPLATE
309	PPAINT-11	PUTTY TOUCH-UP PAINT
310	P0656X310	MACHINE ID LABEL
311	PPAINT-1	GRIZZLY GREEN TOUCH-UP PAINT
312	PPAINT-16	RED TOUCH-UP PAINT

## **⚠️ WARNING**

Safety labels warn about machine hazards and ways to prevent injury. The owner of this machine **MUST** maintain the original location and readability of the labels on the machine. If any label is removed or becomes unreadable, **REPLACE** that label before using the machine again. Contact Grizzly at (800) 523-4777 or [www.grizzly.com](http://www.grizzly.com) to order new labels.





# MODEL G0656 8" JOINTER w/BUILT-IN MOBILE BASE MANUAL UPDATE

This update covers changes made to the machine after the owner's manual was printed. All page number references refer to the owner's manual for this machine. Keep this update with your owner's manual for future reference. *If you have questions, contact Tech Support at (570) 546-9663 or by email at [techsupport@grizzly.com](mailto:techsupport@grizzly.com).*

## Machine Inventory (See Page 11)

The fence assembly and fence bracket are no longer pre-installed on the jointer assembly by the factory for shipping, as shown in **Figure 3** on G0656 Manual **Page 11**. These items have been added to the machine inventory (**Figure 1**). Refer to the owner's manual for the rest of the inventory.

Wood Crate (Figure 1):	Qty
A. Fence Bracket .....	1
B. Fence Assembly .....	1

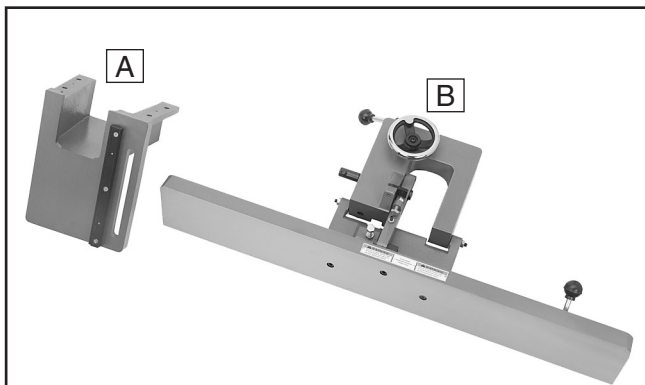

**Figure 1.** New inventory items.

The items below have been added to the original list of included assembly fasteners:

Assembly Fasteners	Qty
• Cap Screws M8-1.25 x 35 (Fence) .....	4
• Lock Washers 8mm (Fence) .....	4
• Flat Washers 8mm (Fence).....	4
• Key 4 x 4 x 12 (Right Handwheel) .....	1

## Clean Up (See Page 13)

The following sliding surfaces must be cleaned:

- Fence carriage
- Fence bracket

## Assembly (See Page 14)

Assembly of the fence bracket, fence carriage assembly, and handwheels has changed. **Steps 2-5** below replace **Steps 15-17** on **Page 15** of the G0656 Owner's Manual.

1. Follow **Steps 1-14** on **Pages 14 & 15**.
2. Align the mounting holes on the fence bracket and jointer, and fasten with the M8-1.25 x 35 cap screws, flat washers and lock washers, as shown in **Figure 2**. Do not fully tighten the fasteners yet.

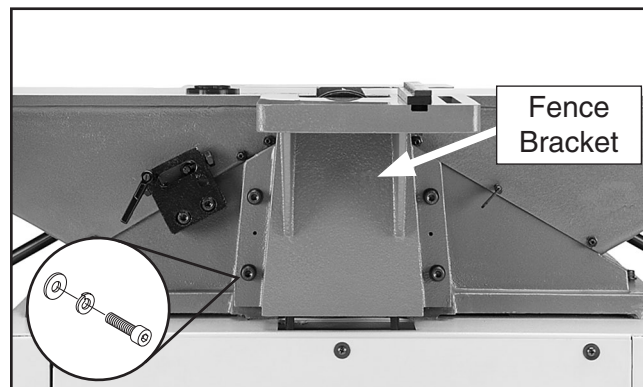

**Figure 2.** Fence bracket installed.

3. Remove the locking nut and flat washer (Figure 3) from the fence lock handle bolt (Figure 4), place the fence assembly over the jointer tables and fence bracket, and insert the bolt through the fence bracket slot, making sure the carriage fits over the key (Figure 3).

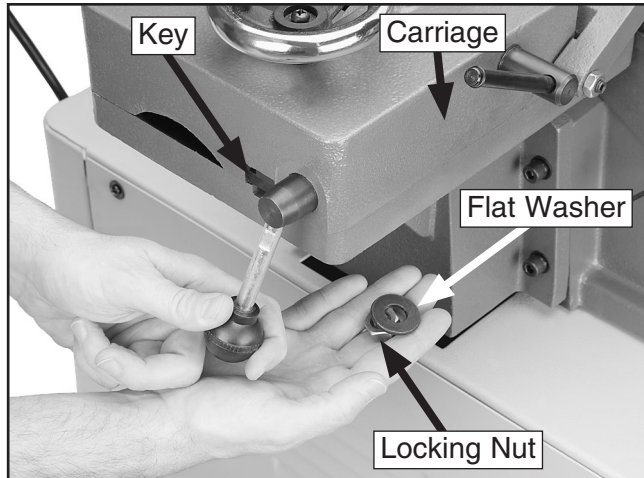

Figure 3. Fence locking nut and washer removed.

4. Secure the fence lock handle bolt with the locking nut and flat washer removed in Step 3, as shown in Figure 4, and final tighten the fence bracket.

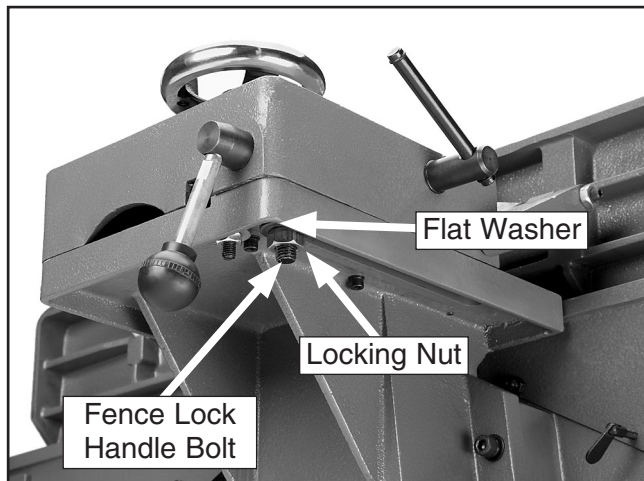

Figure 4. Fence installed.

5. Install the round-slotted handwheel onto the right shaft with the 4 x 4 x 12 key, and install the square-slotted handwheel onto the left shaft, using the cap screws and flat washers already mounted on the handwheel shafts.

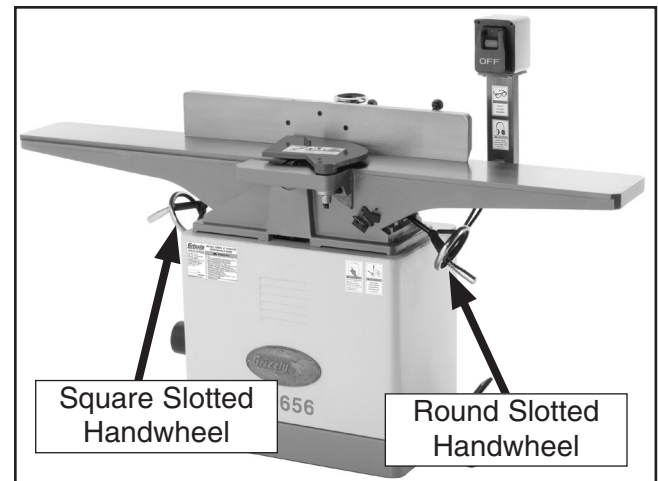

Figure 5. Handwheels installed.

6. Perform Steps 18-26 on Pages 15 & 16.

# *Grizzly* *Industrial, Inc.*®

## MODEL G0656 8" JOINTER w/BUILT-IN MOBILE BASE OWNER'S MANUAL



COPYRIGHT © NOVEMBER, 2007 BY GRIZZLY INDUSTRIAL, INC.  
**WARNING: NO PORTION OF THIS MANUAL MAY BE REPRODUCED IN ANY SHAPE  
OR FORM WITHOUT THE WRITTEN APPROVAL OF GRIZZLY INDUSTRIAL, INC.**

#BL10198 PRINTED IN CHINA



## **WARNING!**

**This manual provides critical safety instructions on the proper setup, operation, maintenance and service of this machine/equipment.**

**Failure to read, understand and follow the instructions given in this manual may result in serious personal injury, including amputation, electrocution or death.**

**The owner of this machine/equipment is solely responsible for its safe use. This responsibility includes but is not limited to proper installation in a safe environment, personnel training and usage authorization, proper inspection and maintenance, manual availability and comprehension, application of safety devices, blade/cutter integrity, and the usage of personal protective equipment.**

**The manufacturer will not be held liable for injury or property damage from negligence, improper training, machine modifications or misuse.**



## **WARNING!**

**Some dust created by power sanding, sawing, grinding, drilling, and other construction activities contains chemicals known to the State of California to cause cancer, birth defects or other reproductive harm. Some examples of these chemicals are:**

- **Lead from lead-based paints.**
- **Crystalline silica from bricks, cement and other masonry products.**
- **Arsenic and chromium from chemically-treated lumber.**

**Your risk from these exposures varies, depending on how often you do this type of work. To reduce your exposure to these chemicals: Work in a well ventilated area, and work with approved safety equipment, such as those dust masks that are specially designed to filter out microscopic particles.**

# Table of Contents

<b>INTRODUCTION.....</b>	<b>2</b>	Basic Controls.....	20
Foreword.....	2	Stock Inspection & Requirements .....	21
Contact Info .....	2	Squaring Stock .....	22
Machine Data Sheet .....	3	Surface Planing .....	22
Identification.....	5	Edge Jointing .....	23
<b>SECTION 1: SAFETY.....</b>	<b>6</b>	Bevel Cutting .....	24
Safety Instructions for Machinery .....	6	Rabbet Cutting.....	25
Additional Safety Instructions for Jointers .....	8	<b>SECTION 5: ACCESSORIES.....</b>	<b>27</b>
<b>SECTION 2: CIRCUIT REQUIREMENTS .....</b>	<b>9</b>	<b>SECTION 6: MAINTENANCE.....</b>	<b>30</b>
220V Operation.....	9	Schedule .....	30
<b>SECTION 3: SETUP .....</b>	<b>10</b>	Lubrication .....	30
Setup Safety .....	10	Cleaning.....	31
Items Needed for Setup.....	10	V-Belts .....	31
Unpacking .....	10	<b>SECTION 7: SERVICE .....</b>	<b>32</b>
Inventory .....	11	Troubleshooting .....	32
Hardware Recognition Chart .....	12	Inspecting Knives.....	34
Clean Up.....	13	Setting/Replacing Knives.....	34
Site Considerations.....	13	Setting Infeed Table.....	36
Assembly .....	14	Setting Fence Stops .....	37
Dust Collection.....	17	Adjusting Gibs.....	38
Setting Outfeed Table Height .....	17	Wiring Diagram .....	39
Test Run .....	18	Table Parts Breakdown .....	40
Recommended Adjustments.....	18	Fence Parts Breakdown .....	42
Tighten V-Belt .....	18	Stand Parts Breakdown .....	44
<b>SECTION 4: OPERATIONS .....</b>	<b>19</b>	Label Placement.....	46
Operation Safety .....	19	<b>WARRANTY AND RETURNS .....</b>	<b>49</b>
Jointer Overview .....	19		

# INTRODUCTION

---

---

## Foreword

---

---

We are proud to offer the Model G0656 8" Jointer with Built-In Mobile Base. This machine is part of a growing Grizzly family of fine woodworking machinery. When used according to the guidelines set forth in this manual, you can expect years of trouble-free, enjoyable operation and proof of Grizzly's commitment to customer satisfaction.

The specifications, drawings, and photographs illustrated in this manual represent the Model G0656 when the manual was prepared. However, owing to Grizzly's policy of continuous improvement, changes may be made at any time with no obligation on the part of Grizzly.

For your convenience, we always keep current Grizzly manuals available on our website at **www.grizzly.com**. Any updates to your machine will be reflected in these manuals as soon as they are complete. Visit our site often to check for the latest updates to this manual!

## Contact Info

---

---

If you have any comments regarding this manual, please write to us at the address below:

Grizzly Industrial, Inc.  
c/o Technical Documentation Manager  
P.O. Box 2069  
Bellingham, WA 98227-2069  
Email: manuals@grizzly.com

We stand behind our machines. If you have any service questions or parts requests, please call or write us at the location listed below.

Grizzly Industrial, Inc.  
1203 Lycoming Mall Circle  
Muncy, PA 17756  
Phone: (570) 546-9663  
Fax: (800) 438-5901  
E-Mail: techsupport@grizzly.com  
Web Site: <http://www.grizzly.com>







# MACHINE DATA SHEET

Customer Service #: (570) 546-9663 • To Order Call: (800) 523-4777 • Fax #: (800) 438-5901

## MODEL G0656 8" JOINTER W/ MOBILE BASE

### Product Dimensions:

Weight ..... 465 lbs.  
 Length/Width/Height ..... 72½" x 26" x 47¼"  
 Foot Print (Length/Width)..... 26¾" x 16½"

### Shipping Dimensions:

#### Box #1

Type..... Wood Crate  
 Content..... Machine  
 Weight ..... 435 lbs.  
 Length/Width/Height ..... 25" x 80¾" x 14½"

#### Box #2

Type..... Cardboard  
 Content..... Stand  
 Weight ..... 167 lbs.  
 Length/Width/Height ..... 18¾" x 29¼" x 26⅝"

### Electrical:

Switch..... ON/OFF Push Button with Large OFF Paddle  
 Switch Voltage ..... 220V  
 Cord Length ..... 6 ft.  
 Cord Gauge ..... 14 gauge  
 Minimum Circuit Size ..... 20A  
 Plug..... Yes

### Motors:

#### Main

Type..... TEFC Capacitor Start Induction  
 Horsepower ..... 3 HP  
 Voltage ..... 220V  
 Phase ..... Single  
 Amps ..... 15A  
 Speed ..... 3450 RPM  
 Cycle..... 60 Hz  
 Number Of Speeds..... 1  
 Power Transfer ..... V-Belt Drive  
 Bearings ..... Shielded and Lubricated

### Main Specifications:

#### Operation Information

Fence Length ..... 34⅞"  
 Fence Width ..... 1¼"  
 Fence Height ..... 5"  
 Fence Stops ..... 45, 90, and 135 deg.



**Cutting Capacities**

Bevel Jointing .....	Left & Right 45 deg.
Maximum Width of Cut .....	8"
Maximum Depth of Cut .....	1/8"
Maximum Rabbeting Depth.....	1/2"
Number of Cuts Per Minute.....	20,000

**Knife Information**

Number of Knives.....	4
Knife Type .....	HSS
Knife Length .....	8"
Knife Width .....	3/4"
Knife Thickness .....	1/8"
Knife Adjustment .....	Jack Screws
Correct Knife Protrusion Above Cutterhead.....	0.063"

**Cutterhead Information**

Cutterhead Type.....	4 Knife
Cutterhead Diameter .....	3"
Cutterhead Speed .....	5000 RPM

**Table Information**

Table Length .....	72 1/2"
Table Width .....	9"
Floor to Table Height.....	33 1/2"
Table Adjustment Type .....	Handwheels

**Construction**

Body Assembly Construction .....	Cast Iron
Stand Construction.....	One-Piece Steel Cabinet
Fence Assembly Construction.....	Cast Iron
Guard Construction .....	Die Cast Metal
Dovetailed Ways on Bed.....	Adjustable
Parallelogram .....	No

**Other Information**

Number of Dust Ports .....	1
Dust Port Size .....	4"

**Other Specifications:**

Country Of Origin .....	China
Warranty.....	1 Year
Serial Number Location .....	ID Label on Left Side of Stand
Assembly Time .....	1 Hour

**Features:**

- Built in Easy-to-Use Mobile Base
- Included Push Blocks
- Top Mount Switch Controls
- Super Long 72 1/2" Bed
- Handwheel Controlled Fence Adjustment
- Rabbeting Table



# Identification

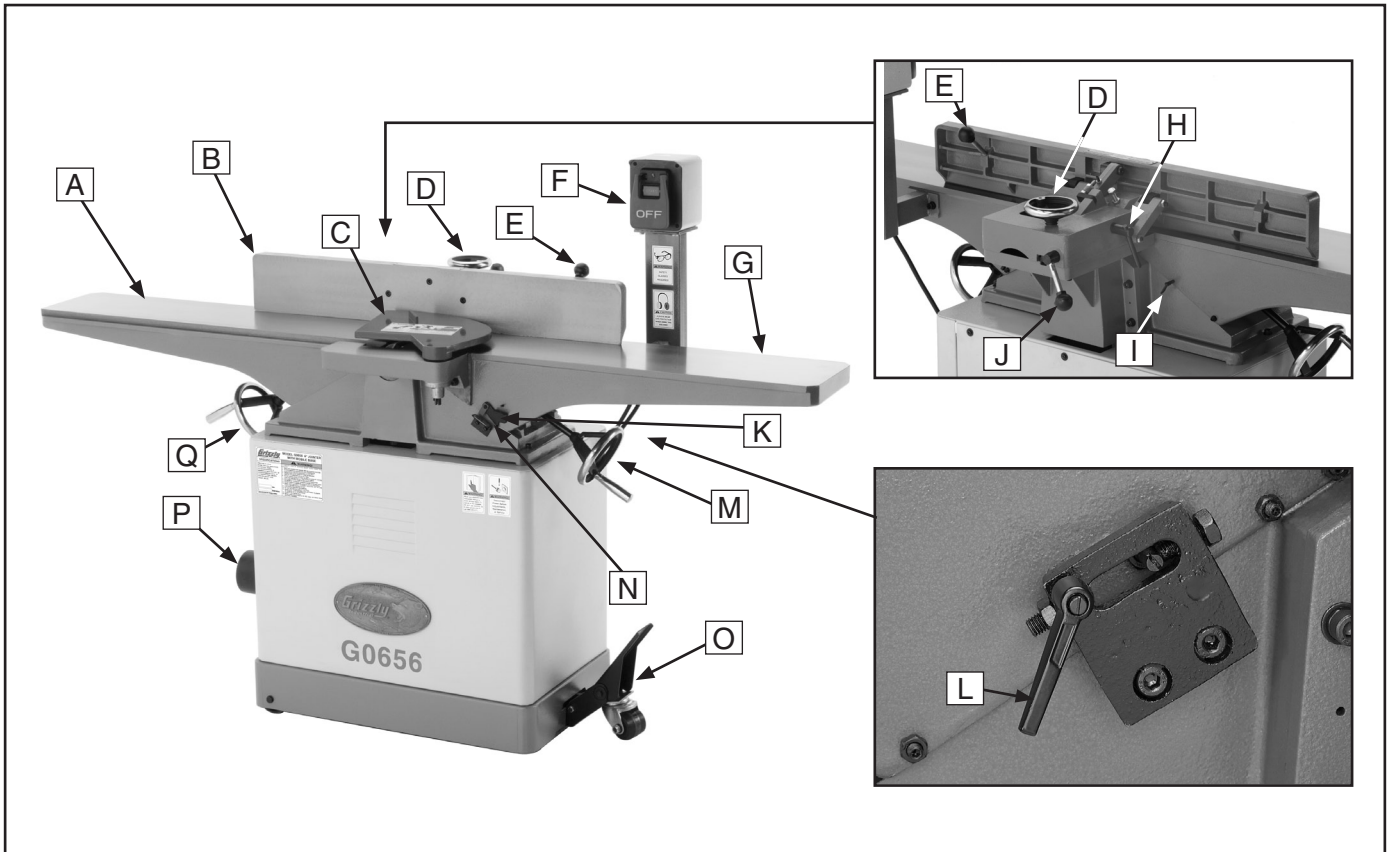

**Figure 1.** Model G0656 identification.

- A. Outfeed Table
- B. Fence
- C. Cutterhead Guard
- D. Fence Adjustment Wheel
- E. Fence Tilt Handle
- F. ON/OFF Switch
- G. Infeed Table
- H. Fence Tilt Lock
- I. Outfeed Table Lock
- J. Fence Lock
- K. Depth Stop Lever
- L. Infeed Table Lock
- M. Infeed Table Handwheel
- N. Depth Scale
- O. Wheel Assembly
- P. Dust Port
- Q. Outfeed Table Handwheel



# SECTION 1: SAFETY

## WARNING

### For Your Own Safety, Read Instruction Manual Before Operating this Machine

The purpose of safety symbols is to attract your attention to possible hazardous conditions. This manual uses a series of symbols and signal words intended to convey the level of importance of the safety messages. The progression of symbols is described below. Remember that safety messages by themselves do not eliminate danger and are not a substitute for proper accident prevention measures.



Indicates an imminently hazardous situation which, if not avoided, **WILL** result in death or serious injury.



Indicates a potentially hazardous situation which, if not avoided, **COULD** result in death or serious injury.



Indicates a potentially hazardous situation which, if not avoided, **MAY** result in minor or moderate injury. It may also be used to alert against unsafe practices.

**NOTICE**

This symbol is used to alert the user to useful information about proper operation of the machine.

## WARNING

### Safety Instructions for Machinery

- 1. READ THE ENTIRE MANUAL BEFORE STARTING MACHINERY.** Machinery presents serious injury hazards to untrained users.
- 2. ALWAYS USE ANSI APPROVED SAFETY GLASSES WHEN OPERATING MACHINERY.** Everyday eyeglasses only have impact resistant lenses—they are NOT safety glasses.
- 3. ALWAYS WEAR A NIOSH APPROVED RESPIRATOR WHEN OPERATING MACHINERY THAT PRODUCES DUST.** Most types of dust (wood, metal, etc.) can cause severe respiratory illnesses.
- 4. ALWAYS USE HEARING PROTECTION WHEN OPERATING MACHINERY.** Machinery noise can cause permanent hearing loss.
- 5. WEAR PROPER APPAREL. DO NOT** wear loose clothing, gloves, neckties, rings, or jewelry that can catch in moving parts. Wear protective hair covering to contain long hair and wear non-slip footwear.
- 6. NEVER OPERATE MACHINERY WHEN TIRED OR UNDER THE INFLUENCE OF DRUGS OR ALCOHOL.** Be mentally alert at all times when running machinery.



# WARNING

## Safety Instructions for Machinery

7. **ONLY ALLOW TRAINED AND PROPERLY SUPERVISED PERSONNEL TO OPERATE MACHINERY.** Make sure operation instructions are safe and clearly understood.
8. **KEEP CHILDREN AND VISITORS AWAY.** Keep all children and visitors a safe distance from the work area.
9. **MAKE WORKSHOP CHILDPROOF.** Use padlocks, master switches, and remove start switch keys.
10. **NEVER LEAVE WHEN MACHINE IS RUNNING.** Turn power **OFF** and allow all moving parts to come to a complete stop before leaving machine unattended.
11. **DO NOT USE IN DANGEROUS ENVIRONMENTS.** DO NOT use machinery in damp, wet locations, or where any flammable or noxious fumes may exist.
12. **KEEP WORK AREA CLEAN AND WELL LIGHTED.** Clutter and dark shadows may cause accidents.
13. **USE A GROUNDED EXTENSION CORD RATED FOR THE MACHINE AMPERAGE.** Grounded cords minimize shock hazards. Undersized cords create excessive heat. Always replace damaged extension cords.
14. **ALWAYS DISCONNECT FROM POWER SOURCE BEFORE SERVICING MACHINERY.** Make sure switch is in OFF position before reconnecting.
15. **MAINTAIN MACHINERY WITH CARE.** Keep blades sharp and clean for best and safest performance. Follow instructions for lubricating and changing accessories.
16. **MAKE SURE GUARDS ARE IN PLACE AND WORK CORRECTLY BEFORE USING MACHINERY.**
17. **REMOVE ADJUSTING KEYS AND WRENCHES.** Make a habit of checking for keys and adjusting wrenches before turning machinery **ON**.
18. **CHECK FOR DAMAGED PARTS BEFORE USING MACHINERY.** Check for binding or misaligned parts, broken parts, loose bolts, and any other conditions that may impair machine operation. Repair or replace damaged parts before operation.
19. **USE RECOMMENDED ACCESSORIES.** Refer to the instruction manual for recommended accessories. Improper accessories increase risk of injury.
20. **DO NOT FORCE MACHINERY.** Work at the speed for which the machine or accessory was designed.
21. **SECURE WORKPIECE.** Use clamps or a vise to hold the workpiece when practical. A secured workpiece protects your hands and frees both hands to operate the machine.
22. **DO NOT OVERREACH.** Maintain stability and balance at all times.
23. **MANY MACHINES CAN EJECT WORKPIECES TOWARD OPERATOR.** Know and avoid conditions that cause the workpiece to "kickback."
24. **ALWAYS LOCK MOBILE BASES (IF USED) BEFORE OPERATING MACHINERY.**
25. **CERTAIN DUST MAY BE HAZARDOUS** to the respiratory systems of people and animals, especially fine dust. Be aware of the type of dust you are exposed to and always wear a respirator designed to filter that type of dust.



# WARNING

## Additional Safety Instructions for Jointers

- 1. JOINTER KICKBACK.** "Kickback" is when the workpiece is thrown off the jointer table by the force of the cutterhead. Always use push blocks and safety glasses to reduce the likelihood of injury from "kickback." If you do not understand what kickback is, or how it occurs, **DO NOT** operate this machine.
- 2. CUTTERHEAD ALIGNMENT.** Keep the top edge of the outfeed table aligned with the cutterhead knife or insert at top dead center (TDC) to avoid kickback and personal injuries.
- 3. PUSH BLOCKS.** Always use push blocks whenever surface planing. Never pass your hands directly over the cutterhead without a push block.
- 4. WORKPIECE SUPPORT.** Supporting the workpiece adequately at all times while cutting is crucial for making safe cuts and avoiding injury. Never attempt to make a cut with an unstable workpiece.
- 5. KICKBACK ZONE.** The "kickback zone" is the path directly through the end of the infeed table. Never stand or allow others to stand in this area during operation.
- 6. SAFE KNIFE PROJECTION.** Knives that project more than 0.125" from the cutterhead may become loose or damaged during operation. Always make sure knives are properly set and well tightened in the cutterhead.
- 7. MAXIMUM CUTTING DEPTH.** The maximum cutting depth for one pass is 1/8". To minimize kickback, never attempt any single cut deeper than this!
- 8. JOINTING WITH THE GRAIN.** Jointing against the grain or jointing end grain is dangerous and could produce chatter or excessive chip out. Always joint with the grain.
- 9. KEEPING GUARDS IN PLACE.** With the exception of rabbeting, all operations must be performed with the cutterhead guard in place. After rabbeting, be sure to replace the guard, to reduce the risk of serious injury.
- 10. PROPER CUTTING.** When cutting, always keep the workpiece moving toward the outfeed table until the workpiece has passed completely over the cutterhead. Never back the work toward the infeed table, to reduce the risk of kickback.
- 11. USING GOOD STOCK.** Jointing safety begins with your lumber. Inspect your stock carefully before you feed it over the cutterhead. Never joint a board that has loose knots, nails, or staples. If you have any doubts about the stability or structural integrity of your stock, **DO NOT** joint it!

### WARNING

Like all machines there is danger associated with this machine. Accidents are frequently caused by lack of familiarity or failure to pay attention. Use this machine with respect and caution to lessen the possibility of operator injury. If normal safety precautions are overlooked or ignored, serious personal injury may occur.

### CAUTION

No list of safety guidelines can be complete. Every shop environment is different. Always consider safety first, as it applies to your individual working conditions. Use this and other machinery with caution and respect. Failure to do so could result in serious personal injury, damage to equipment, or poor work results.



# SECTION 2: CIRCUIT REQUIREMENTS

## 220V Operation

### **!WARNING**

Serious personal injury could occur if you connect the machine to power before completing the setup process. **DO NOT** connect the machine to the power until instructed later in this manual.

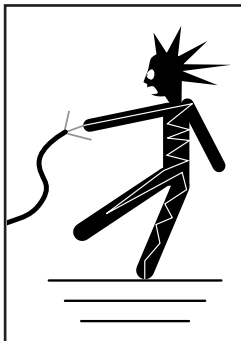

### **!WARNING**

Electrocution or fire could result if machine is not grounded and installed in compliance with electrical codes. Compliance **MUST** be verified by a qualified electrician!

### Full Load Amperage Draw

Motor Draw at 220V ..... 15 Amps

### Minimum Circuit Requirements

You **MUST** connect your machine to a grounded circuit that is rated for the amperage given below. Never replace a circuit breaker on an existing circuit with one of higher amperage without consulting a qualified electrician to ensure compliance with wiring codes. **If you are unsure about the wiring codes in your area or you plan to connect your machine to a shared circuit, consult a qualified electrician.**

Minimum Circuit Size.....20 Amps

### Power Connection Device

The type of plug required to connect your machine to power depends on the type of service you currently have or plan to install. We recommend using the plug shown in **Figure 2**.

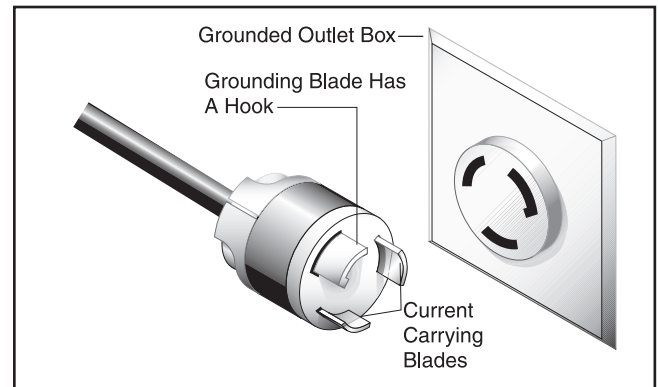

Figure 2. NEMA L6-20 plug and receptacle.

### Extension Cords

Using extension cords may reduce the life of the motor. Instead, place the machine near a power source. If you must use an extension cord:

- Use at least a 12 gauge cord that does not exceed 50 feet in length!
- The extension cord must also have a ground wire and plug pin.
- A qualified electrician **MUST** size cords over 50 feet long to prevent motor damage.





# SECTION 3: SETUP

## Setup Safety

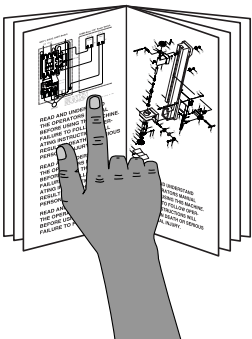

**!WARNING**  
This machine presents serious injury hazards to untrained users. Read through this entire manual to become familiar with the controls and operations before starting the machine!



**!WARNING**  
Wear safety glasses during the entire setup process!



**!WARNING**  
This machine and its components are very heavy. Get lifting help or use power lifting equipment such as a forklift to move heavy items.

## Items Needed for Setup

The following items are needed to complete the setup process, but are not included with your machine:

Description	Qty
• Safety Glasses (for each person) .....	1
• Wrench or Socket 17mm.....	2
• Wrench or Socket 13mm.....	2
• Extra Person for Lifting Help .....	1
• Straightedge (see <b>Page 28</b> ) .....	1
• Phillips Head Screwdriver .....	1
• Dust Collection System .....	1
• 4" Dust Hose (length as needed).....	1
• 4" Hose Clamp .....	1

## Unpacking

Your machine was carefully packaged for safe transportation. Remove the packaging materials from around your machine and inspect it. If you discover the machine is damaged, *please immediately call Customer Service at (570) 546-9663 for advice.*

Save the containers and all packing materials for possible inspection by the carrier or its agent. *Otherwise, filing a freight claim can be difficult.*

When you are completely satisfied with the condition of your shipment, inventory the contents.



# Inventory

The following is a description of the main components shipped with your machine. Lay the components out to inventory them.

**Note:** *If you can't find an item on this list, check the mounting location on the machine or examine the packaging materials carefully. Occasionally we pre-install certain components for shipping purposes.*

<b>Wood Crate: (Figure 3)</b>	<b>Qty</b>
<b>A.</b> Jointer Assembly.....	1
<b>B.</b> Cutterhead Guard.....	1
<b>C.</b> Handwheels.....	2
<b>D.</b> Handles .....	2
<b>E.</b> Fence Tilt Lever .....	1
<b>F.</b> Push Blocks.....	2
<b>G.</b> Knife Setting Gauge Hardware Bag	
—Knife Setting Gauge Rod.....	1
—Knife Setting Gauge Foot .....	2
—E-Clip 8mm .....	2
<b>H.</b> Tool Hardware Bag	
—Hex Wrenches 2.5, 3, 4, 6mm .....	1 Each
—Open-end Wrench 8/10, 12/14mm .....	1

<b>Cardboard Box: (Figure 4)</b>	<b>Qty</b>
<b>I.</b> Stand Assembly w/Motor and Door .....	1
<b>J.</b> Pedestal Switch.....	1
<b>K.</b> Wheel Assembly.....	1
<b>L.</b> V-Belt.....	1
<b>M.</b> Dust Port .....	1

<b>Assembly Fasteners</b>	<b>Qty</b>
• Hex Bolt M8-1.25 x 50 (Wheel/Stand) .....	1
• Flat Washer 8mm (Wheel/Stand).....	1
• Hex Bolts M10-1.5 x 55 (Wheel/Stand).....	2
• Flat Washers 10mm (Wheel/Stand) .....	2
• Hex Nuts M10-1.5 (Wheel/Stand) .....	2
• Cap Screws M8-1.25 x 50 (Jointer/Stand) .	3
• Flat Washers 8mm (Jointer/Stand) .....	6
• Lock Washers 8mm (Jointer/Stand).....	3
• Hex Nuts M8-1.25 (Jointer/Stand).....	3
• Flat Washers 6mm (Handwheels).....	2
• Cap Screws M6-1 x 12 (Handwheels) .....	2
• Set Screw M5-.8 x 12 (Cutterhead Guard)	1
• Cap Screws M8-1.25 x 25 (Pedestal) .....	2
• Lock Washers (Pedestal) .....	2
• Flat Washers (Pedestal).....	2
• Phillips Head Screws	
M5-.8 x 16 (Dust Port).....	4
• Flat Washers 5mm (Dust Port) .....	4

G0656 8" Jointer with Built-In Mobile Base

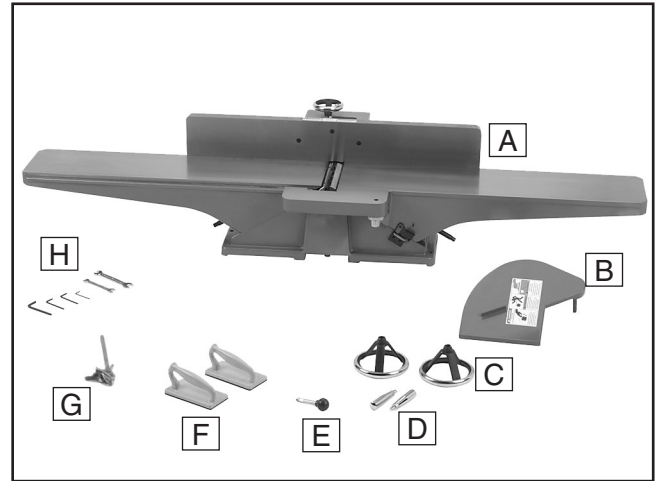

**Figure 3.** Box 1 inventory contents.

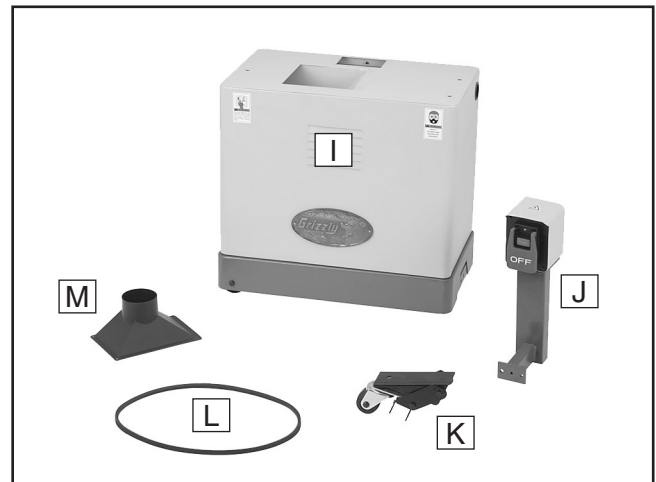

**Figure 4.** Box 2 inventory contents.

- Cap Screws M8-1.25 x 25 (Fence Suppt.) . 4
- Flat Washers 8mm (Fence Support)..... 4
- Lock Washers 8mm (Fence Support) .....

In the event that any nonproprietary parts are missing (e.g. a nut or a washer), we would be glad to replace them, or for the sake of expediency, replacements can be obtained at your local hardware store.

	<p><b>⚠ WARNING</b>  <b>SUFFOCATION HAZARD!</b>          Immediately discard all plastic bags and packing materials to eliminate choking/suffocation hazards for children and animals.</p>
--	--



# Hardware Recognition Chart

USE THIS CHART TO MATCH UP HARDWARE DURING THE ASSEMBLY PROCESS.

MEASURE BOLT DIAMETER BY PLACING INSIDE CIRCLE

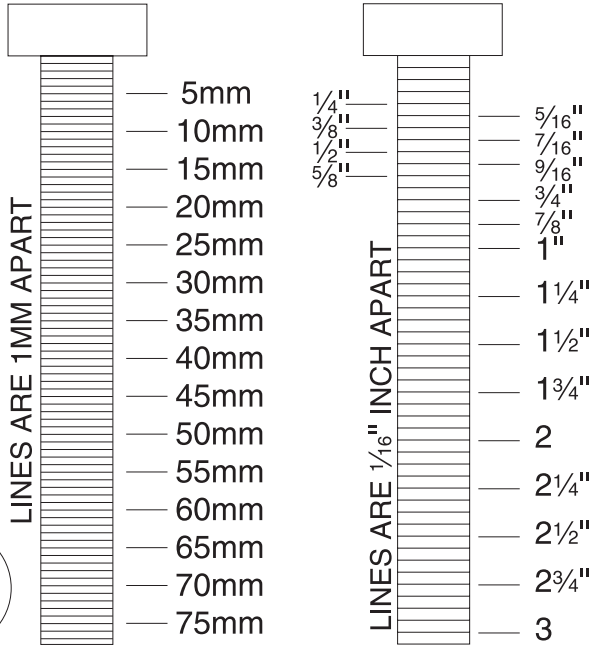
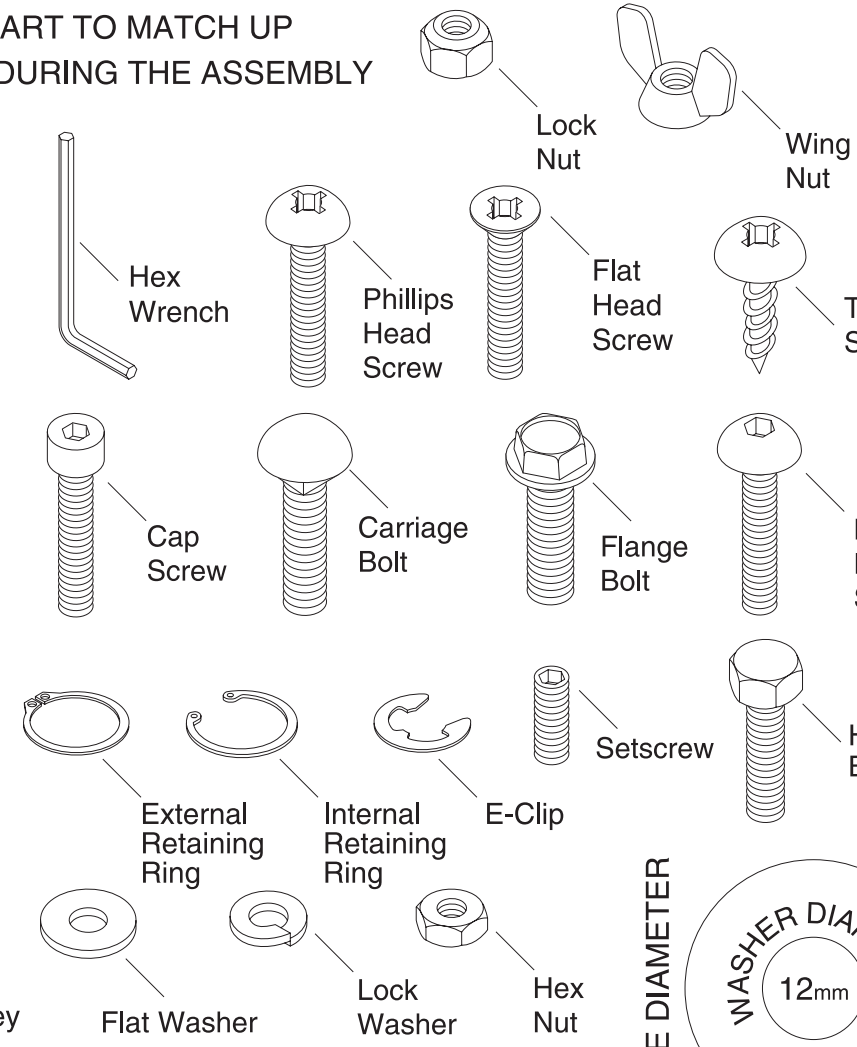
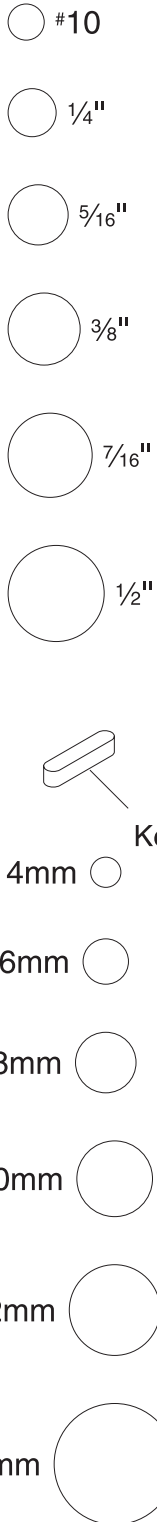

WASHERS ARE MEASURED BY THE INSIDE DIAMETER

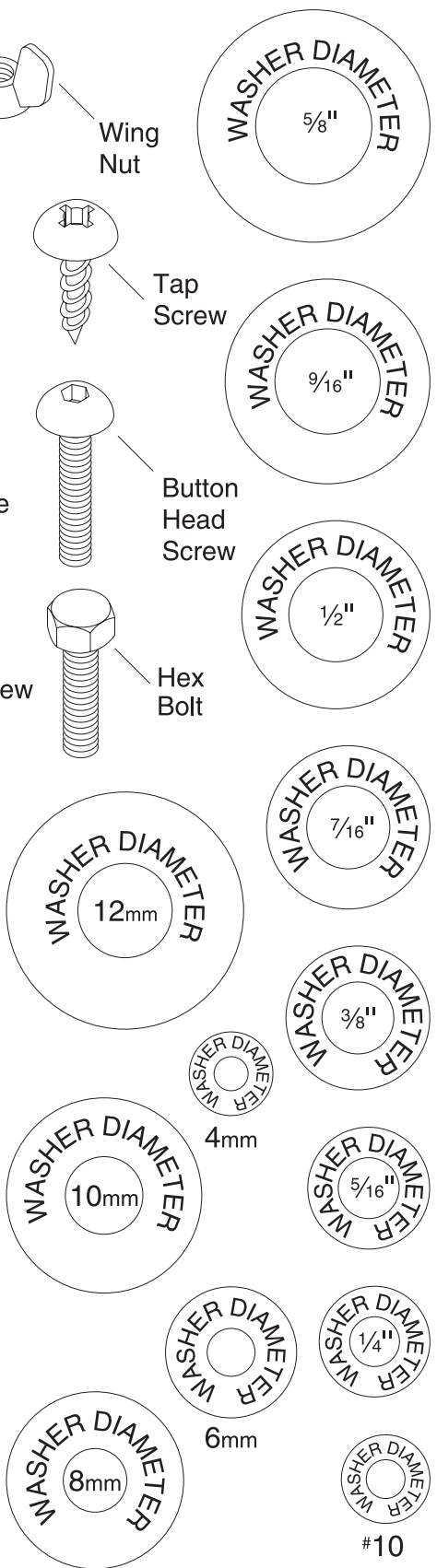

# Clean Up

The unpainted surfaces are coated with a waxy oil to prevent corrosion during shipment. Remove this protective coating with a solvent cleaner or citrus-based degreaser such as Grizzly's G7895 Citrus Degreaser. To clean thoroughly, some parts must be removed. **For optimum performance from your machine, clean all moving parts or sliding contact surfaces.** Avoid chlorine-based solvents, such as acetone or brake parts cleaner that may damage painted surfaces. Always follow the manufacturer's instructions when using any type of cleaning product.

To access the sliding surfaces, remove the lock nut (**Figure 5**) and flat washer securing the fence lock handle, and remove the fence from the jointer unit.

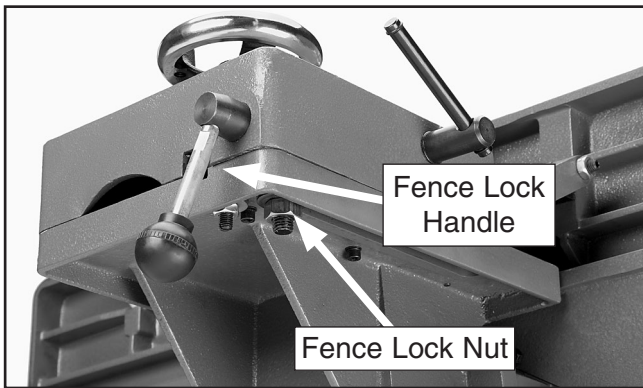

**Figure 5.** Removing the fence lock nut so the sliding surfaces can be cleaned.

Once the sliding surfaces of the fence are clean, reassemble the fence to the jointer and secure the lock handle with the lock nut and washer.

	<p><b>! WARNING</b> Gasoline and petroleum products have low flash points and can explode or cause fire if used to clean machinery. <b>DO NOT</b> use these products to clean the machinery.</p>
--	--

# Site Considerations

## Floor Load

Refer to the **Machine Data Sheet** for the weight and footprint specifications of your machine. Some residential floors may require additional reinforcement to support both the machine and operator.

## Placement Location

Consider existing and anticipated needs, size of material to be processed through each machine, and space for auxiliary stands, work tables or other machinery when establishing a location for your new machine. See **Figure 6** for the minimum working clearances.

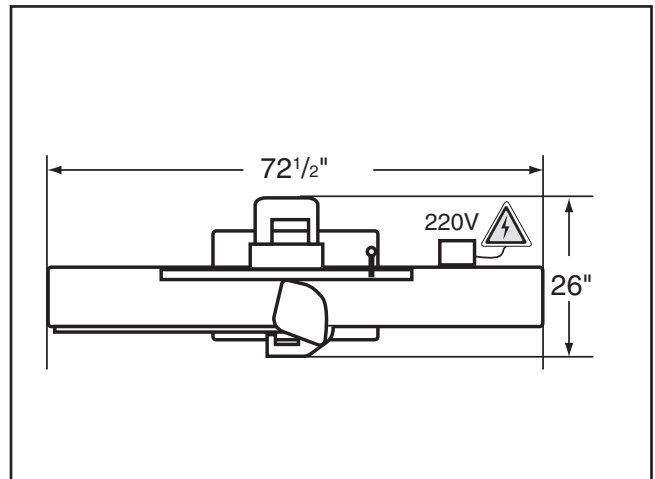

**Figure 6.** Minimum working clearances.

	<p><b>! CAUTION</b> Children and visitors may be seriously injured if unsupervised around this machine. Lock entrances to the shop or disable start switch or power connection to prevent unsupervised use.</p>
--	---



# Assembly

## To assemble the jointer:

1. Carefully lay the stand on its side so you can access the underside.
2. Bolt the wheel assembly to the stand with the provided hardware, as shown in **Figure 7**.

**Note:** Refer to the **Inventory List** on **Page 11** for a list of components needed for assembly.

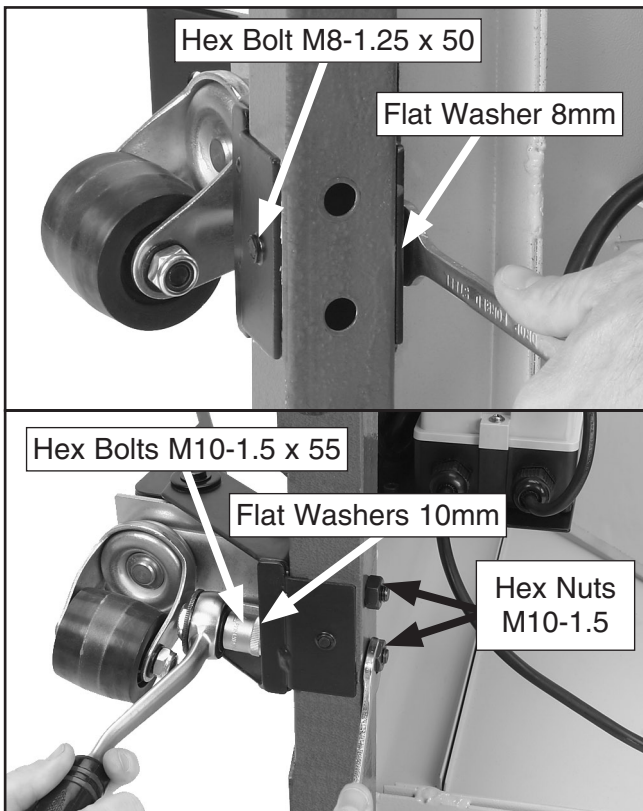

**Figure 7.** Example of bolting the wheel assembly to the stand.

3. Turn the stand rightside up.

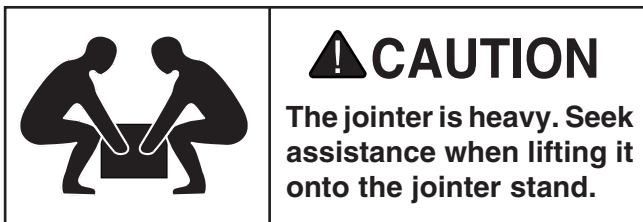

4. Remove the rear access panel from the jointer stand.

5. With the help of an assistant, lift the jointer onto the stand.
6. Align the mounting holes on the jointer and stand.
7. Secure the jointer to the stand with the M8-1.25 x 50 cap screws, washers, and hex nuts, as shown in **Figure 8**.

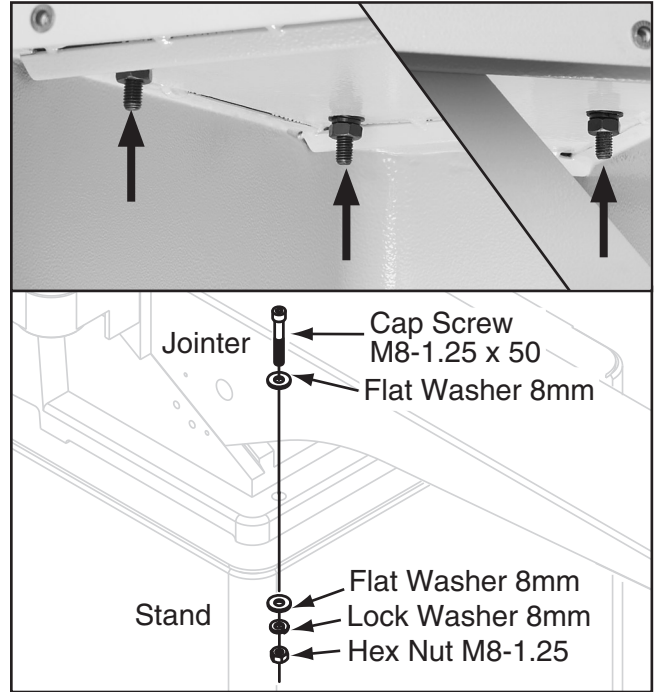

**Figure 8.** Jointer secured to stand.

8. Using a 13mm wrench, loosen the motor bracket fasteners shown in **Figure 9**.

**Note:** *DO NOT* completely remove the motor mount bolts.

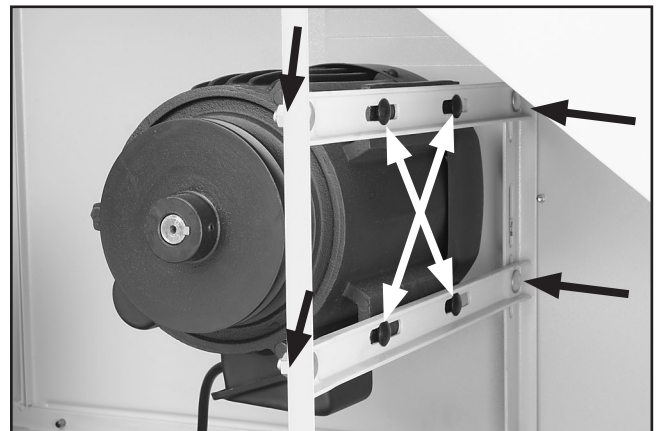
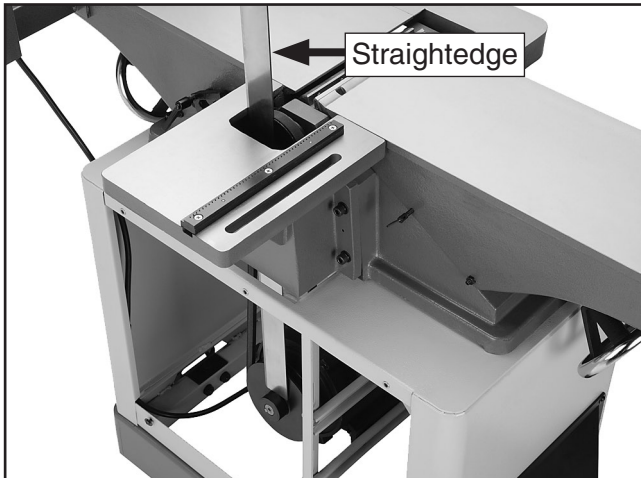

**Figure 9.** Motor bracket fasteners (black arrows); motor mount fasteners (white arrows).





9. Slide the motor upward, and place the V-belt around the cutterhead pulley and the motor pulley.
10. Slide the motor down to rest on the V-belt.
11. Place a straightedge against both pulleys (**Figure 10**) and check the alignment of the two pulleys to make sure that they are aligned and that the V-belt is straight up and down (see **Figure 11**).



**Figure 10.** Checking belt alignment.

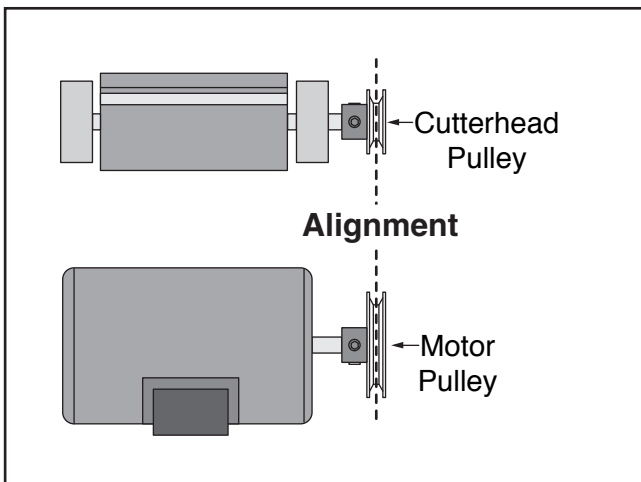

**Figure 11.** Pulleys aligned.

- If the pulleys are aligned, tighten the motor bracket fasteners and go to **Step 15**.
- If the pulleys are NOT aligned, perform **Steps 12–14**.

12. Remove the V-belt and loosen the motor mount fasteners (see **Figure 9**).

13. Shift the motor horizontally as needed to align the motor pulley with the cutterhead pulley, then replace the V-belt.
14. Tighten the motor mount fasteners.
15. Secure the infeed and outfeed handwheels with the cap screws and flat washers already mounted on the handwheel shafts, as shown in **Figure 12**.



**Figure 12.** Securing the handwheel handle.

16. Secure the handwheel handles to each of the the handwheels, as shown in **Figure 12**.
17. Install the fence tilt lever, as shown in **Figure 13**.

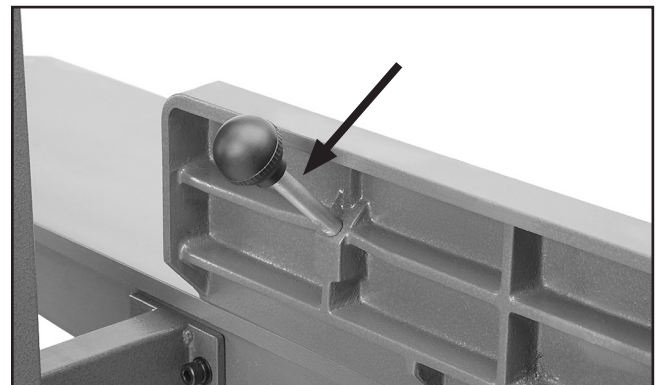

**Figure 13.** Fence tilt lever installed.

18. Slide the cutterhead guard shaft down through the mounting hole on the table.

**Note:** The guard may not fully seat in the hole initially; however, rotating the guard will allow the shaft to fully seat in the hole.



- Using a 2.5mm hex wrench, thread the set screw through the hole in the forked end of the cutterhead guard shaft (**Figure 14**).

**Note:** Thread the set screw far enough to prevent the guard from being pulled out.

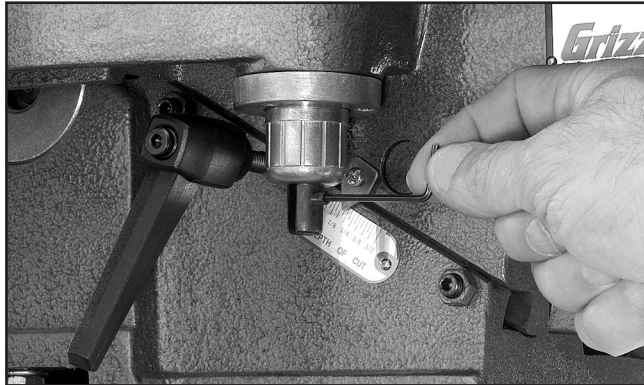

**Figure 14.** Example of installing cutterhead guard set screw.

- Raise the fence and rotate the guard one revolution counter-clockwise as it appears from the top. Hold the guard in position.
- Lower the fence and allow the guard to swing back against the fence.

## **NOTICE**

**The cutterhead guard must always return to the closed position whenever it is moved.**

- Test the guard by pulling it back and letting it go.
  - The guard should snap back over the cutterhead without dragging across the table.
  - If the guard drags across the table, loosen the set screw, raise the guard until it won't drag, then tighten the set screw.
  - If the guard does not snap back, remove it and repeat **Steps 18–21**.
- Attach the pedestal switch with the cap screws, lock washers, and flat washers, as shown in **Figure 15**.



**Figure 15.** Attaching pedestal switch to stand.

- Thread the excess switch cord through the access hole in the stand and connect it to the motor cord.
- Assemble the knife setting gauge using the knife setting gauge rod, feet and 8mm e-clips, as shown in **Figure 16**.

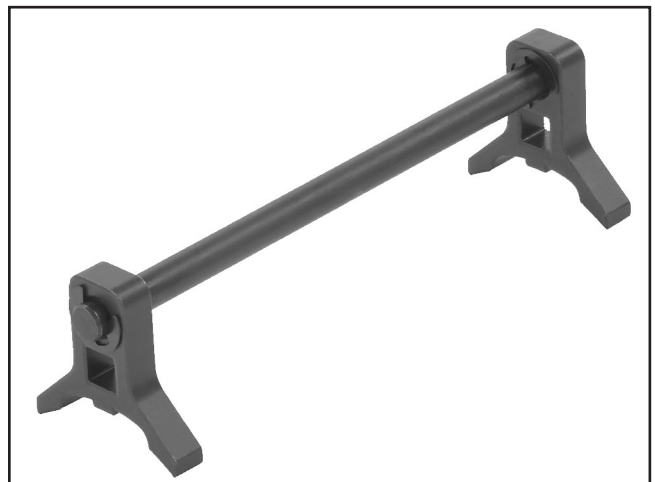

**Figure 16.** Knife setting gauge assembly.

- Replace the rear access panel on the stand.





# Dust Collection

## CAUTION

**DO NOT** operate the Model G0656 without an adequate dust collection system. This jointer creates substantial amounts of wood dust while operating. Failure to use a dust collection system can result in short and long-term respiratory illness.

### Recommended CFM at Dust Port: 400 CFM

*Do not confuse this CFM recommendation with the rating of the dust collector. To determine the CFM at the dust port, you must consider these variables: (1) CFM rating of the dust collector, (2) hose type and length between the dust collector and the machine, (3) number of branches or wyes, and (4) amount of other open lines throughout the system. Explaining how to calculate these variables is beyond the scope of this manual. Consult an expert or purchase a good dust collection "how-to" book.*

### To connect a dust collection hose:

1. Install the dust port as shown in **Figure 17**, using the four M5-.8 x 16 Phillips head screws and flat washers.

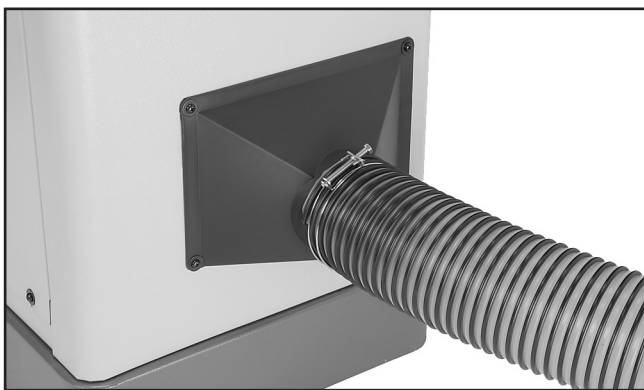

**Figure 17.** Dust hose attached to dust port.

2. Fit the 4" dust hose over the dust port, as shown in **Figure 17**, and secure in place with a hose clamp.
3. Tug the hose to make sure it does not come off. **Note:** A tight fit is necessary for proper performance.



# Setting Outfeed Table Height

The outfeed table height **MUST** be level with the knives when they are at top-dead-center. If the outfeed table is set too low, the workpiece will be tapered from front to back. If the outfeed table is set too high, the workpiece will hit the edge of the outfeed table during operation, increasing the chance of kickback.

### To set the outfeed table height:

1. **DISCONNECT JOINTER FROM POWER SOURCE!**
2. Move the cutterhead guard out of the way or remove it, and open the rear access panel.
3. Place a straightedge on the outfeed table so it extends over the cutterhead and rotate the cutterhead pulley until one of the knives is at top-dead-center (TDC), as illustrated in **Figure 18**.

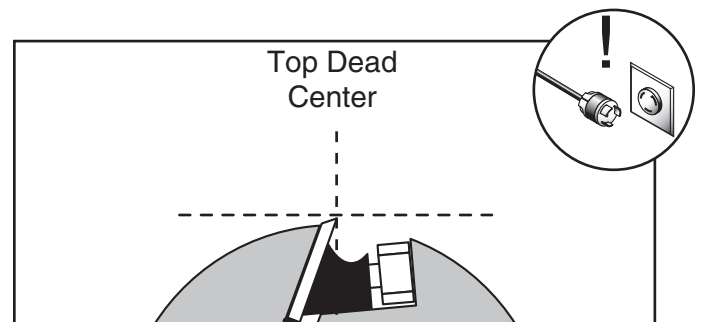

**Figure 18.** Cutterhead knife at top-dead-center.

4. When correctly set, the knife will just touch the straightedge when the knife is at its highest point of rotation, as shown in **Figure 19**.

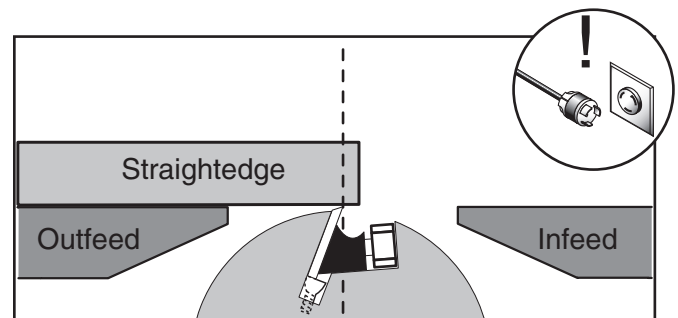

**Figure 19.** Using a straightedge to align outfeed table height with knife at TDC.

—If your outfeed table is correctly set, no adjustments are necessary.

—If the knife lifts the straightedge off the table or the table is below the straightedge, adjust the outfeed table height with the handwheel until the straightedge just touches a knife at its highest point of rotation.

5. Lock the outfeed table, reinstall the cutterhead guard, and close the rear access panel.

## Test Run

---

Once the assembly is complete, test run your machine to make sure it runs properly.

If, during the test run, you cannot easily locate the source of an unusual noise or vibration, stop using the machine immediately, then review the **Troubleshooting** on **Page 32**.

If you still cannot remedy a problem, contact our Tech Support at (570) 546-9663 for assistance.

### To test run the machine:

1. Make sure you have read the safety instructions at the beginning of the manual and that the machine is setup properly.
2. Make sure all tools and objects used during set up are cleared away from the machine.
3. Connect the machine to the power source.
4. Turn the machine **ON**.
5. Listen for abnormal noises or actions and watch for vibration. The machine should run smoothly.  
  
—Strange or unusual noises must be investigated and corrected before operating the machine further. Always disconnect the machine from power when investigating or correcting potential problems.

6. Turn the machine **OFF**.

## Recommended Adjustments

---

For your convenience, the adjustments listed below have been performed at the factory and no further setup is required to operate your machine.

However, because of the many variables involved with shipping, we recommend that you at least verify the following adjustments to ensure the best possible results from your new machine.

Step-by-step instructions for these adjustments can be found in **SECTION 7: SERVICE**.

### Factory adjustments that should be verified:

1. Knife Settings (**Page 34**).
2. Depth Scale Calibration (**Page 36**).
3. Fence Stop Accuracy (**Page 37**).

## Tighten V-Belt

---

The final step in the setup process must be done after approximately 16 hours of operation. During this first 16 hours, the V-belt will stretch and seat into the pulley grooves. After this 16 hours, you must retension the V-belt to avoid slippage and burn out. Refer to **Page 31** when you are ready to perform this important adjustment.

**Note:** *Pulleys and belts can get hot. This is a normal condition. Allow them to cool before making adjustments.*

*A small amount of black belt dust at the bottom of the belt housing is normal during the life of the machine and does not indicate a problem with the machine or V-belt.*



# SECTION 4: OPERATIONS

## Operation Safety

### **!WARNING**

Damage to your eyes, lungs, and ears could result from using this machine without proper protective gear. Always wear safety glasses, a respirator, and hearing protection when operating this machine.

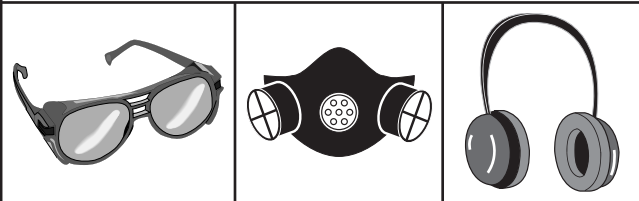

### **!WARNING**

Loose hair and clothing could get caught in machinery and cause serious personal injury. Keep loose clothing and long hair away from moving machinery.

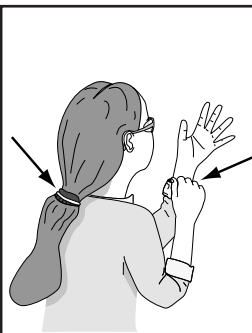

### **!WARNING**

Lock the mobile base wheel before operating the jointer! Operating the jointer with the wheel unlocked may cause loss of control and serious personal injury.

### **NOTICE**

If you have never used this type of machine or equipment before, WE STRONGLY RECOMMEND that you read books, trade magazines, or get formal training before beginning any projects. Regardless of the content in this section, Grizzly Industrial will not be held liable for accidents caused by lack of training.

## Jointer Overview

A jointer is primarily used to flatten the face or edge of a workpiece, which is required when properly "squaring up" a workpiece for later construction or joining multiple pieces with glue. A jointer can also cut bevels, rabbets, and other specialized cuts with various jigs or fixtures.

The primary components of the jointer are the cutterhead, outfeed table, infeed table, and fence. A typical cut on a jointer is made by firmly holding a workpiece against the infeed table and fence, then moving the workpiece over the cutterhead while using the fence as a guide. As the workpiece moves over the cutterhead, the knives make many shallow cuts that "shave" off the surface of the workpiece. After moving over the cutterhead, the workpiece is received by the outfeed table, which along with the fence, continue to guide the workpiece across a flat plane until it completely passes the cutterhead. Since only a small amount of the workpiece is removed during a jointer cut, most jointer cuts are repeated many times to yield a desired result.

In order for the jointer to cut properly, all the knives in the cutterhead must be set at the same height in the cutterhead.

Additionally, the outfeed table must be even with the cutterhead knives at their highest point of rotation to keep the freshly cut portion of the workpiece in the same plane as it was cut, which is what yields a flat workpiece.

The position of the infeed table relative to the outfeed table is what controls the cutting depth. If the infeed table is  $\frac{1}{16}$ " lower than the outfeed table, then  $\frac{1}{16}$ " of the workpiece will be removed by the cutterhead as the workpiece passes from the infeed table to the outfeed table.



Since the workpiece is held firmly against the fence as it passes over the cutterhead, the fence controls the angle of the cut. The jointer fence can be moved 45° in either direction from square and locked in place anywhere within this range. The jointer fence also features stops that allow it to be quickly set at 45°, 90°, and 125°.

## Basic Controls

This section covers the basic controls used during routine operations.

**START Button:** Starts motor.

**STOP Paddle:** Stops motor when pushed in.

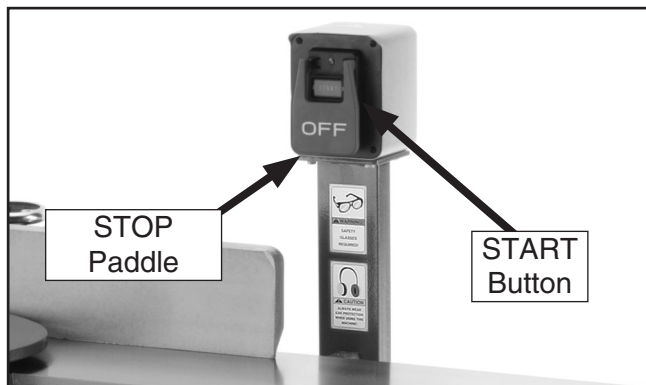

Figure 20. START/STOP controls.

**Table Movement:** To move the infeed or outfeed tables, loosen the table locks (Figure 21), move the tables with the table handwheels, then tighten the table locks. To adjust the preset range of movement for the infeed table, refer to Page 36.

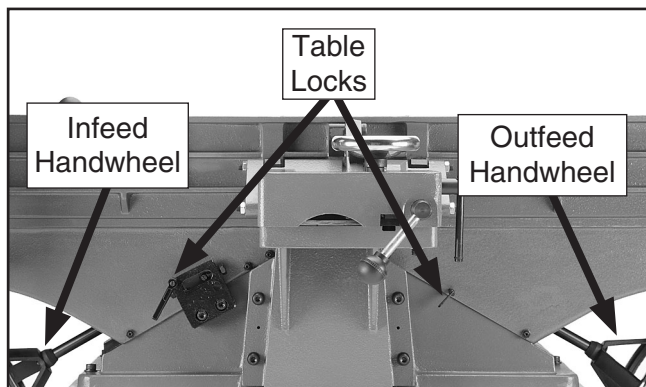

Figure 21. Table control locations.

**Fence Movement:** The fence has a lock that keeps it in position (Figure 22). To move the fence, loosen the lock and turn the fence adjustment wheel to slide the fence where needed.

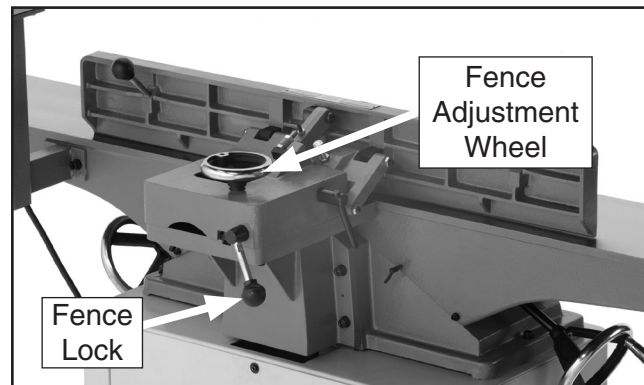

Figure 22. Fence lock location.

**Fence Tilting:** The tilt lock (Figure 23) secures the fence at any position in the available range. The swing stop locks the fence tilt for 90° cuts. Two positive stops stop the fence at 45° inward and 45° outward for common 45° bevel cuts. Even when the fence is resting against the positive stops, the tilt lock must be tightened before cutting. Also, the swing stop must be disengaged for 45° outward bevel cuts.

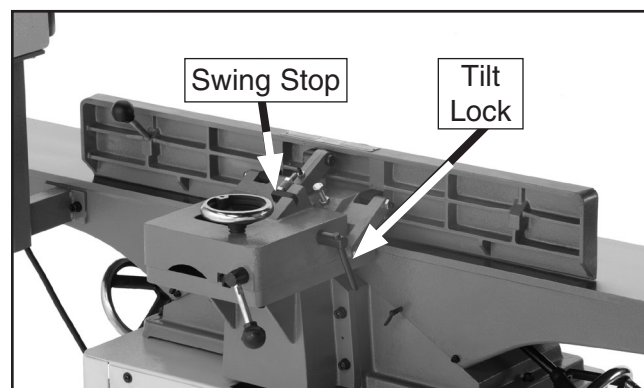

Figure 23. Tilt lock and swing stop locations.



# Stock Inspection & Requirements

Here are some rules to follow when choosing and jointing stock:

- **DO NOT joint or surface plane stock that contains large or loose knots.** Injury to the operator or damage to the workpiece can occur if a knot becomes dislodged during the cutting operation.
- **DO NOT joint or surface plane against the grain direction.** Cutting against the grain increases the likelihood of stock kickback, as well as tear-out on the workpiece.
- **Jointing and surface planing with the grain produces a better finish and is safer for the operator.** Cutting with the grain is described as feeding the stock on the jointer so the grain points down and toward you as viewed on the edge of the stock (**Figure 24**).

**Note:** *If the grain changes direction along the edge of the board, decrease the cutting depth and make additional passes.*

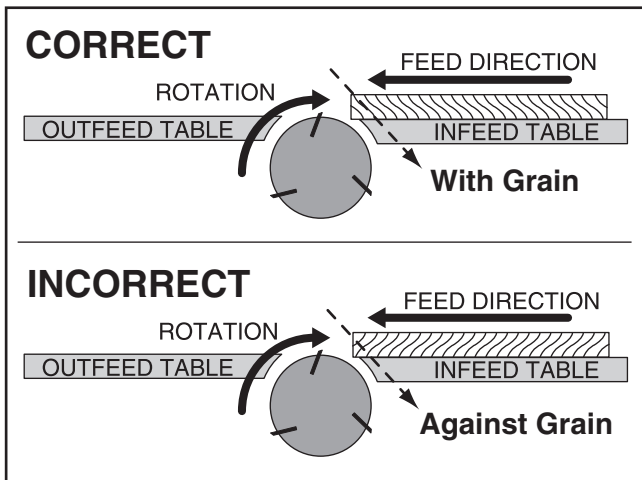

**Figure 24.** Correct and incorrect grain alignment with cutterhead.

- **Only process natural wood fiber through your jointer.** Never joint MDF, particle board, plywood, laminates, metal, stone, tile, glass, plastic or other synthetically made materials.
- **Scrape all glue off of boards before jointing.**
- **Remove foreign objects from the stock.** Make sure that any stock you process with the jointer is clean and free of any dirt, nails, staples, tiny rocks or any other foreign objects, which if they hit the knives and are drawn into the dust collector, may cause a fire hazard. The particles may also damage the knives. Wood stacked on a concrete floor can have small pieces of stone or concrete pressed into the surface.
- **Make sure all stock is sufficiently dried before jointing.** Wood with a moisture content over 20% will cause unnecessary wear on the knives and poor cutting results. Excess moisture can also hasten rust and corrosion.
- **Make sure your workpiece exceeds the minimum dimension requirements (Figure 25) before edge jointing or surface planing, or it may break or kick back during the operation!**

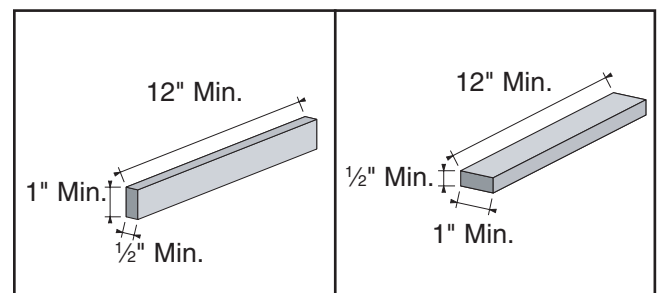

**Figure 25.** Minimum dimensions for edge jointing and surface planing (jointer).





# Squaring Stock

Squaring stock involves four steps performed in the order below:

**1. Surface Plane On The Jointer**—The concave face of the workpiece is surface planed flat with the jointer.

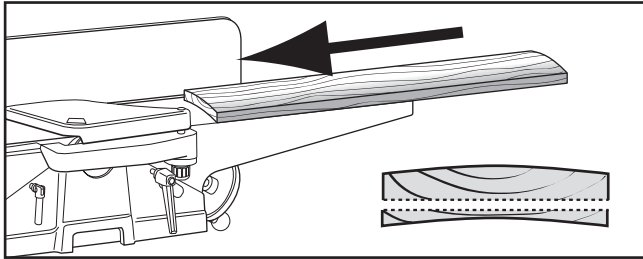

**2. Surface Plane On a Thickness Planer**—The opposite face of the workpiece is surface planed flat with a thickness planer.

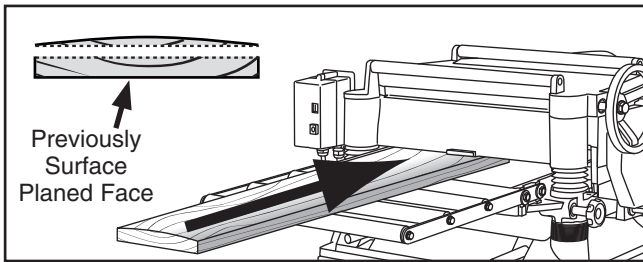

**3. Edge Joint On The Jointer**—The concave edge of the workpiece is jointed flat with the jointer.

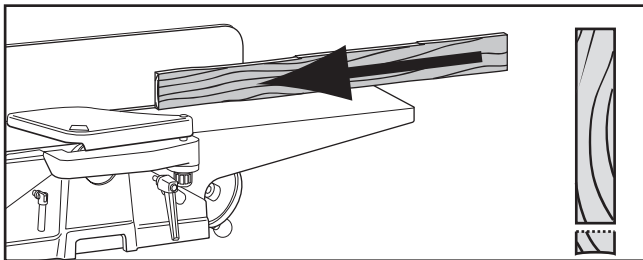

**4. Rip Cut On A Table Saw**—The jointed edge of the workpiece is placed against a table saw fence and the opposite edge cut off.

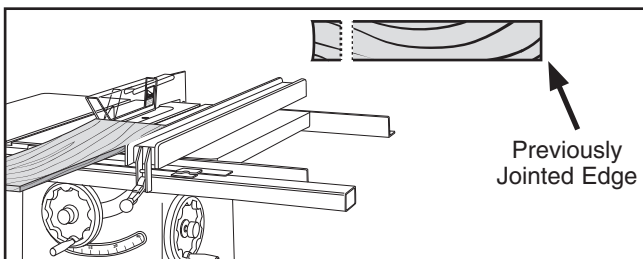

# Surface Planing

The purpose of surface planing on the jointer is to make one flat face on a piece of stock (see **Figures 26 & 27**). This is a necessary step when preparing a workpiece to be run through a planer when squaring stock.

## **NOTICE**

If you are not experienced with a jointer, set the depth of cut to 0", and practice feeding the workpiece across the tables as described. This procedure will better prepare you for the actual operation.

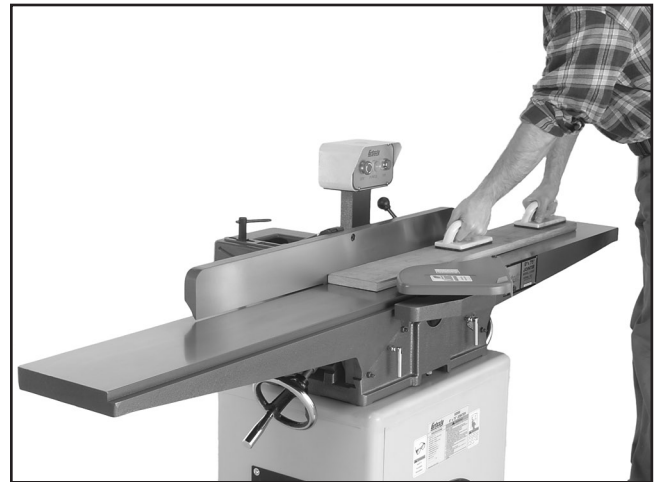

**Figure 26.** Typical surface planing operation.

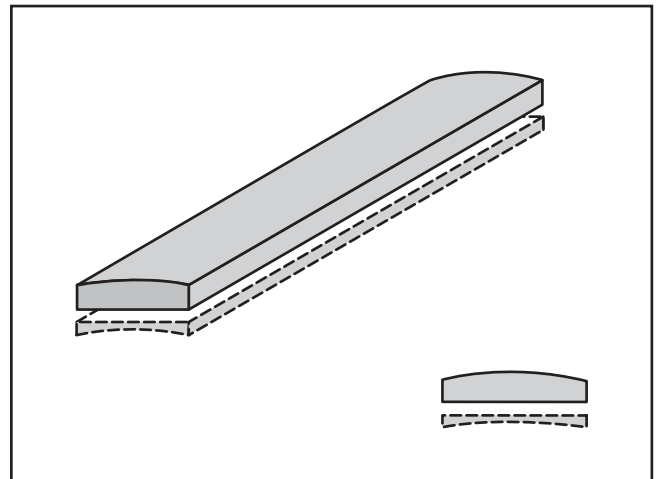

**Figure 27.** Illustration of surface planing results.



## To surface plane on the jointer:

1. Read and understand **SECTION 1: SAFETY**, beginning on **Page 6**.
2. Make sure your stock has been inspected for dangerous conditions as described in the **Stock Inspection & Requirements** instructions, beginning on **Page 21**.
3. Set the cutting depth for your operation. (We suggest  $\frac{1}{32}$ " for surface planing, using a more shallow depth for hard wood species or for wide stock.)
4. Make sure your fence is set to  $90^\circ$ .
5. If your workpiece is cupped (warped), place it so the concave side is face down on the surface of the infeed table.
6. Start the jointer.

### **WARNING**

Failure to use push blocks when surface planing may result in cutterhead contact, which will cause serious personal injury. Always use push blocks to protect your hands when surface planing on the jointer.

7. With a push block in each hand, press the workpiece against the table and fence with firm pressure, and feed the workpiece over the cutterhead.

**Note:** If your leading hand (with push block) gets within 4" of the cutterhead, lift it up and over the cutterhead, and place the push block on the portion of the workpiece that is on the outfeed table. Now, focus your pressure on the outfeed end of the workpiece while feeding, and repeat the same action with your trailing hand when it gets within 4" of the cutterhead. To keep your hands safe, **DO NOT** let them get closer than 4" from the cutterhead when it is moving!

8. Repeat **Step 7** until the entire surface is flat.

## Edge Jointing

The purpose of edge jointing is to produce a finished, flat-edged surface (see **Figures 28 & 29**) that is suitable for joinery or finishing. It is also a necessary step when squaring rough or warped stock.

### **NOTICE**

If you are not experienced with a jointer, set the depth of cut to 0", and practice feeding the workpiece across the tables as described below. This procedure will better prepare you for the actual operation.

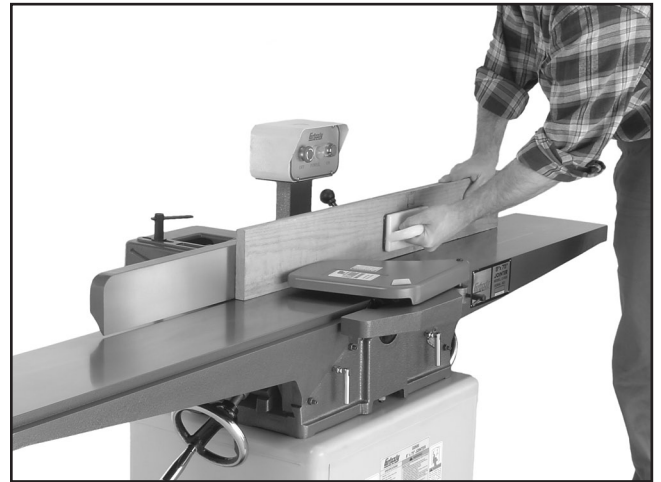

**Figure 28.** Typical edge jointing operation.

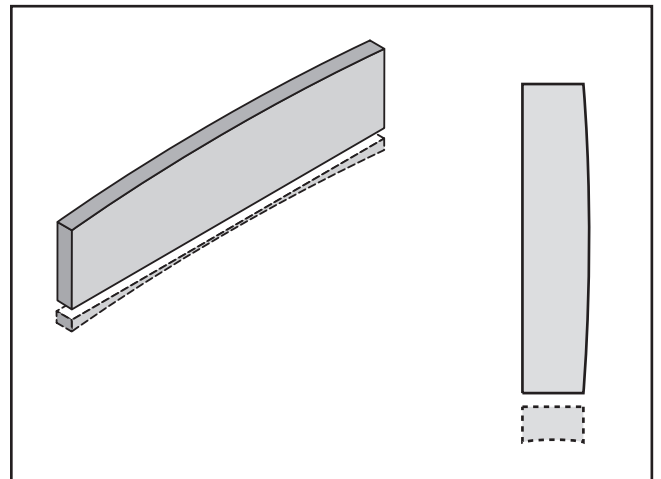

**Figure 29.** Illustration of edge jointing results.



## To edge joint on the jointer:

1. Read and understand **SECTION 1: SAFETY**, beginning on **Page 6**.
2. Make sure your stock has been inspected for dangerous conditions as described in the **Stock Inspection & Requirements** instructions, beginning on **Page 21**.
3. Set the cutting depth for your operation. (We suggest between  $\frac{1}{16}$ " and  $\frac{1}{8}$ " for edge jointing, using a more shallow depth for hard wood species or for wide stock.)
4. Make sure the fence is set to  $90^\circ$ .
5. If your workpiece is cupped (warped), place it so the concave edge is face down on the surface of the infeed table.
6. Start the jointer.
7. With a push block in your leading hand, press the workpiece against the table and fence with firm pressure. Use your trailing hand to guide the workpiece through the cut, and feed the workpiece over the cutterhead.

**Note:** *If your leading hand gets within 4" of the cutterhead, lift it up and over the cutterhead, and place it on the portion of the workpiece that is over the outfeed table. Now, focus your pressure on the outfeed end of the workpiece while feeding, and repeat the same action with your trailing hand when it gets within 4" of the cutterhead. To keep your hands safe, DO NOT let them get closer than 4" from the cutterhead when it is moving!*

8. Repeat **Step 7** until the entire edge is flat.

# Bevel Cutting

The purpose of bevel cutting is to cut a specific angle into the edge of a workpiece (see **Figures 30 & 31**).

The Model G0656 has preset fence stops at  $45^\circ$  inward,  $90^\circ$ , and  $45^\circ$  outward ( $135^\circ$ ). If your situation requires a different angle, the fence can be locked anywhere between these angles.

## NOTICE

**If you are not experienced with a jointer, set the depth of cut to zero, and practice feeding the workpiece across the tables as described below. This procedure will better prepare you for the actual operation.**



**Figure 30.** Typical bevel cutting operation, fence stop at  $45^\circ$  outward.

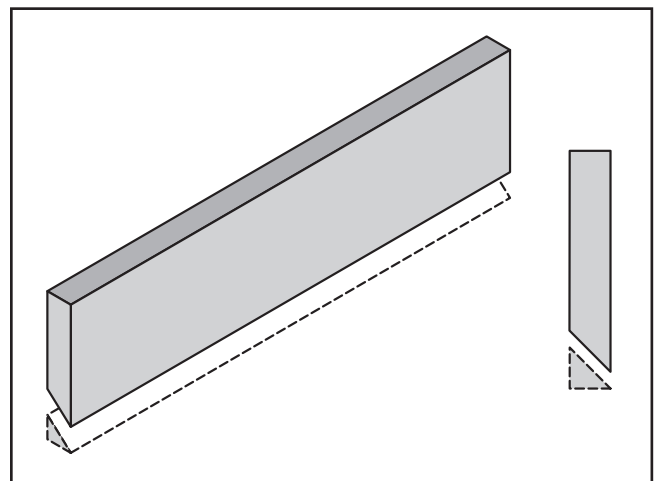

**Figure 31.** Illustration of bevel cutting results.





## To bevel cut on the jointer:

1. Read and understand **SECTION 1: SAFETY**, beginning on **Page 6**.
2. Make sure your stock has been inspected for dangerous conditions as described in the **Stock Inspection & Requirements** instructions, beginning on **Page 21**.
3. Set the cutting depth for your operation. (We suggest between  $\frac{1}{16}$ " and  $\frac{1}{8}$ " for bevel cutting, using a more shallow depth for hard wood species or for wide stock.)
4. Make sure your fence is set to the angle of your desired cut.
5. If your workpiece is cupped (warped), place it so the concave edge is face down on the surface of the infeed table.
6. Start the jointer.
7. With a push block in your leading hand (**Figure 30**), press the workpiece against the table and fence with firm pressure, and feed the workpiece over the cutterhead.

**Note:** *If your leading hand gets within 4" of the cutterhead, lift it up and over the cutterhead, and place the push block on the portion of the workpiece that is on the outfeed table. Now, focus your pressure on the outfeed end of the workpiece while feeding, and repeat the same action with your trailing hand when it gets within 4" of the cutterhead. To keep your hands safe, DO NOT let them get closer than 4" from the cutterhead when it is moving!*

8. Repeat **Step 7** until the angled cut is satisfactory to your needs.

# Rabbet Cutting

The purpose of rabbet cutting is to remove a section of the workpiece edge (see **Figures 32 & 33**). When combined with another rabbet cut edge, the rabbet joints create a simple, yet strong method of joining stock.

## NOTICE

**If you are not experienced with a jointer, set the depth of cut to 0", and practice feeding the workpiece across the tables as described below. This procedure will better prepare you for the actual operation.**

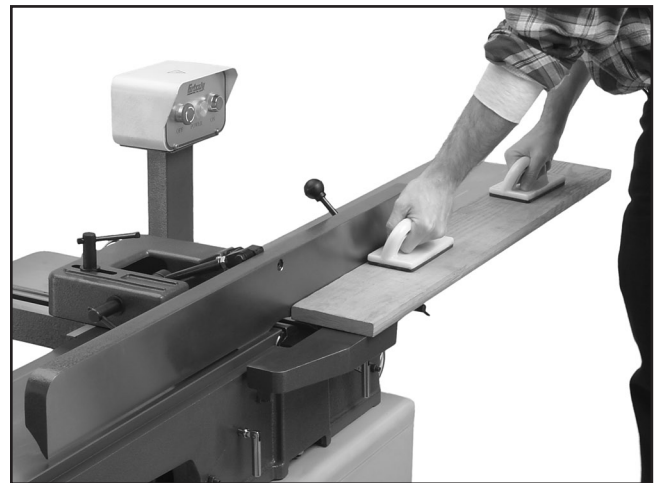

**Figure 32.** Typical rabbet cutting operation.

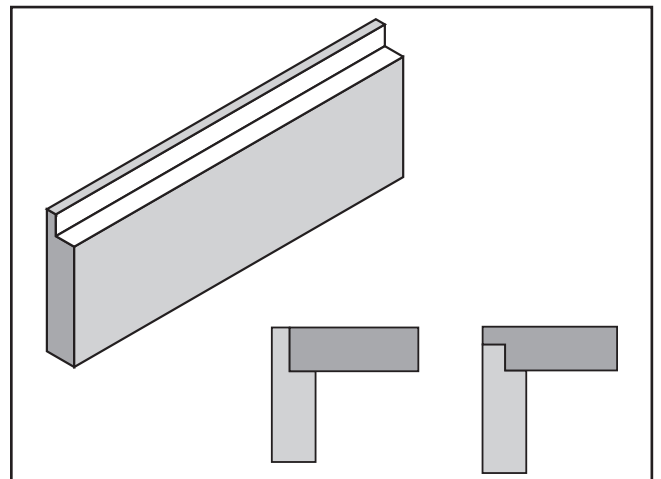

**Figure 33.** Illustration of rabbet cutting effects and a few sample joints.



### To rabbet cut on the jointer:

1. Read and understand **SECTION 1: SAFETY**, beginning on **Page 6**.
2. Make sure your stock has been inspected for dangerous conditions as described in the **Stock Inspection & Requirements** instructions, beginning on **Page 21**.
3. Set the cutting depth for your operation. (We suggest between  $\frac{1}{16}$ " and  $\frac{1}{8}$ " for rabbet cutting, using a more shallow depth for hard wood species or for wide stock.)
4. Remove the cutterhead guard.
5. Make sure your fence is moved forward, so the amount of infeed/outfeed table exposed is the same as the size of your rabbet. Also, make sure your fence is set to  $90^\circ$ .
6. Start the jointer.
7. With a push block in each hand, press the workpiece against the table and fence with firm pressure, and feed the workpiece over the cutterhead.

**Note:** *If your leading hand gets within 4" of the cutterhead, lift it up and over the cutterhead, and place the push block on the portion of the workpiece that is on the outfeed table. Now, focus your pressure on the outfeed end of the workpiece while feeding, and repeat the same action with your trailing hand when it gets within 4" of the cutterhead. To keep your hands safe, DO NOT let them get closer than 4" from the cutterhead when it is moving!*

8. Repeat **Step 7** until the your rabbet is cut to depth.

## **WARNING**

**When the cutterhead guard is removed, attempting any other cut besides a rabbet directly exposes the operator to the moving cutterhead. Always replace the cutterhead guard after rabbet cutting!**



# SECTION 5: ACCESSORIES

## H9815—Power Twist® V-Belt - ½" x 48"

Smooth running with less vibration and noise than solid belts. The Power Twist® V-belt can be customized in minutes to any size—just add or remove sections to fit your needs. Size: ½" x 48"; replaces all "A" sized V-belts. Requires two Power Twist® V-belts to replace the stock V-belt on the Model G0656.

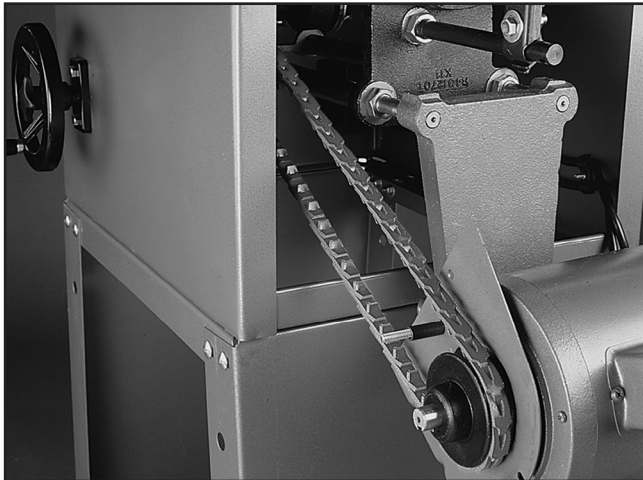

Figure 34. H9815 Power Twist® V-Belt.

## H7765—8" Byrd® Shelix Cutterhead

Made in the USA by Byrd, this indexable carbide insert cutterhead is the best money can buy—period! The inserts are not only placed in a spiral pattern, they are also positioned at an angle so the shearing action leaves a glassy smooth cut on the toughest and most figured woods. Comes with 5 extra replacement inserts. Very nice upgrade!

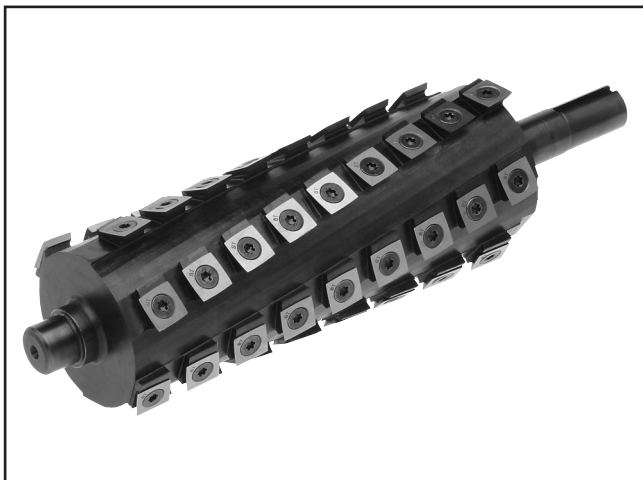

Figure 35. H7765 Byrd Shelix Cutterhead.

## G1753—Jointer Pal® Magnetic Knife Gauge (For HSS & Cobalt Knives)

## G1756—Jointer Pal® Magnetic Knife Gauge (For Carbide Knives)

This patented magnetic knife-setting system lets you set jointer knives in perfect alignment every time! It also allows you to shift nicked knives to get a perfect cut to an accuracy of + or - 0.001".



Figure 36. G1753 Jointer Pal® Knife Gauge.

## G3631—Jointer Knife Hone

Add a razor hone to your planer and jointer knives with this hand-held sharpening device. This handy tool sharpens flat and beveled surfaces quickly and easily. Great for touch-ups.



Figure 37. G3631 Jointer/Planer Knife Hone.

**Call 1-800-523-4777 To Order**



- G5562—SLIPIT® 1 Qt. Gel
- G5563—SLIPIT® 12 oz Spray
- G2871—Boeshield® T-9 12 oz Spray
- G2870—Boeshield® T-9 4 oz Spray
- H3788—G96® Gun Treatment 12 oz Spray
- H3789—G96® Gun Treatment 4.5 oz Spray



**Figure 38.** Recommended products for protecting unpainted cast iron/steel part on machinery.

- H5142—Dispoz-A-Blade® System (Includes 4 Holders & Knife Inserts)
- H5143—Dispoz-A-Blade® Knife Inserts (Set of 4)

Install a Dispoz-A-Blade® Knife system in your new jointer and save up to 70% on knife replacements for the life of your jointer. Each knife insert is double-edged, so you get two knives in one, and is indexed so that all knife inserts can be installed at the same height in just minutes. Very simple and super fast knife changes!

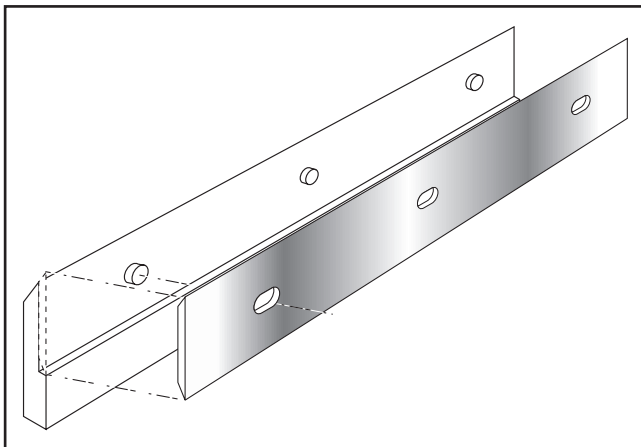

**Figure 39.** Dispoz-A-Blade® Holder and Knife.

- H4982—8" HSS Replacement Jointer Knives (Set of 4)

**H8029—5 Piece Safety Kit**

This kit has four essential jigs. Includes two push blocks, push stick, featherboard and combination saw and router gauge. Featherboard fits 3/8" x 3/4" miter slots. Made of high visibility yellow plastic.



**Figure 40.** H8029 5 Piece Safety Kit.

- G9643—8" Precision Straightedge
- G9644—12" Precision Straightedge
- H2675—16" Precision Straightedge

These grade 00 heavy-duty stainless steel straightedges are manufactured to DIN874 standards for professional results in set-up and inspection work.



**Figure 41.** Straightedges.

**Call 1-800-523-4777 To Order**





- T20501—Face Shield, 4" Crown, Clear
- T20502—Face Shield, 7" Crown, Clear
- T20448—Economy Clear Safety Glasses
- T20452—"Kirova" Anti-Reflective Glasses
- T20456—"Dakura" Clear Safety Glasses
- H0736—Shop Fox® Safety Glasses

These glasses meet ANSI Z87.1-2003 specifications. Buy extras for visitors or employees. You can't be too careful with shop safety!

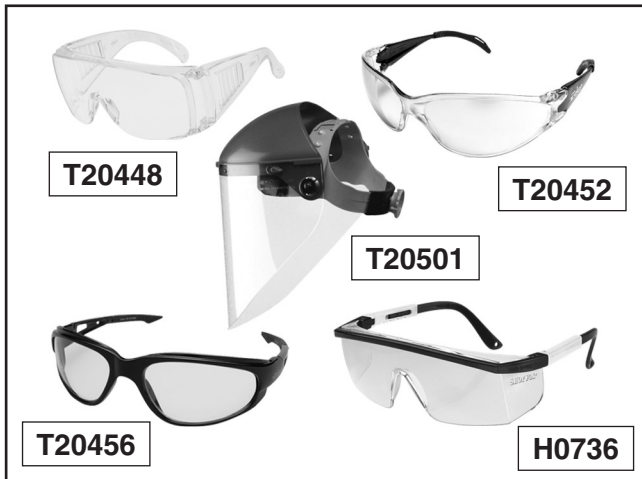

Figure 42. Our most popular eye protection.

- H6175—Power Respirator
- H6892—3M Pre-Filter, 10-Pack
- H6893—Filter Cartridge, 10-Pack, P100

Say goodbye to foggy safety glasses and labored breathing, this battery powered respirator supplies a constant breeze of fresh air all day long. Comes with its own plastic case for clean, sealed storage. Finally, a respirator you can look forward to wearing—at an affordable price!



Figure 43. H6175 Power Respirator.

- T20514—Small Half-Mask Respirator
  - T20515—Medium Half-Mask Respirator
  - T20516—Large Half-Mask Respirator
  - T20511—Pre-Filter P100
  - T20539—Cartridge Filter 2PK P100
  - T20541—Cartridge Filter 2PK P100 & O Vapor
- Wood and other types of dust can cause severe respiratory damage. If you work around dust every-day, a half-mask respirator can greatly reduce your risk. Compatible with safety glasses!

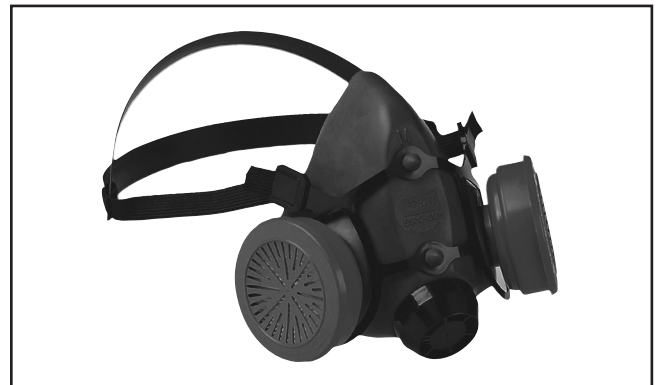

Figure 44. Half-mask respirator with disposable cartridge filters.

- G9256—6" Dial Caliper
- G9257—8" Dial Caliper
- G9258—12" Dial Caliper

Required for jointing, planing, or sanding to critical tolerances. These traditional dial calipers are accurate to 0.001" and can measure outside surfaces, inside surfaces, and heights/depths. Features stainless steel, shock resistant construction and a dust proof display. An absolute treat for the perfectionist!

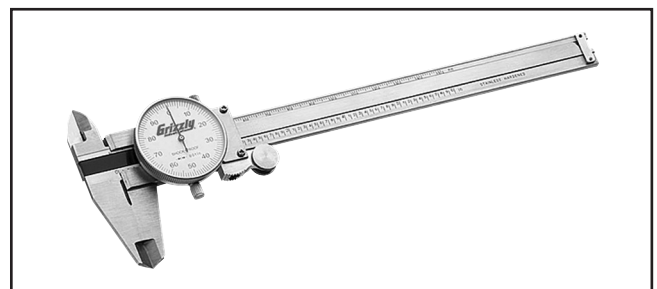
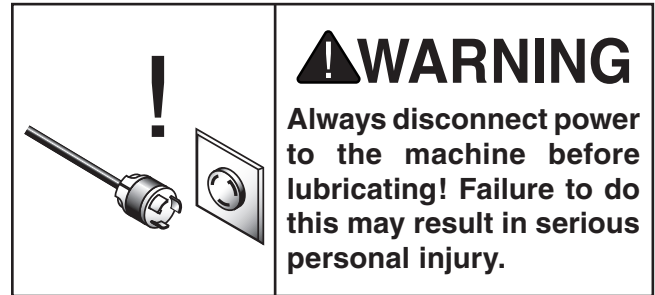
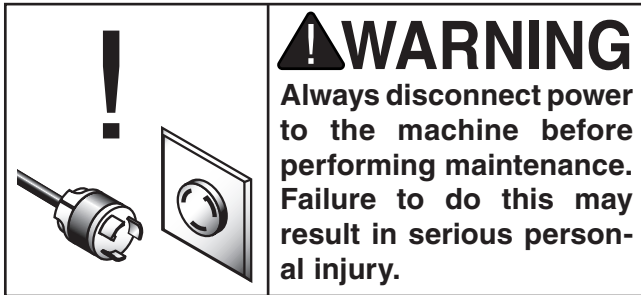

Figure 45. Grizzly® Dial Calipers.

**Call 1-800-523-4777 To Order**



# SECTION 6: MAINTENANCE



## Schedule

For optimum performance from your machine, follow this maintenance schedule and refer to any specific instructions given in this section.

### Daily Check:

- Vacuum all dust on and around the machine.
- Wipe down tables and all other unpainted cast iron with a metal protectant.
- Worn or damaged wires.
- Any other unsafe condition.

### Monthly Check:

- V-belt tension, damage, or wear.
- Clean/vacuum dust buildup from inside cabinet and off motor.

## Lubrication

Since all bearings are sealed and permanently lubricated, simply leave them alone until they need to be replaced. DO NOT lubricate them.

Below is a list of components that require periodic lubrication. Be careful not to over-lubricate these components. Large amounts of lubricant will attract sawdust, causing the metal components to gum up and bind.

**Leadscrews:** Lubricate with light machine oil as needed. See the location shown in **Figure 46** and Part 23 and 48 on **Page 41**. Wipe off excess oil and sawdust with a cloth.

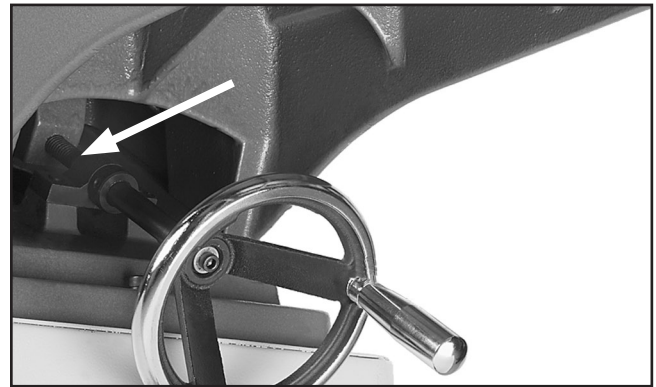

**Figure 46.** Leadscrew lubrication location.

**Gibs:** Lower the infeed and outfeed table to access the gibs. Annually place a couple drops of oil at the top of each gib and move the tables up and down to distribute the oil. See the locations shown in **Figure 47** and Part 66 on **Page 41**. Wipe off excess oil.

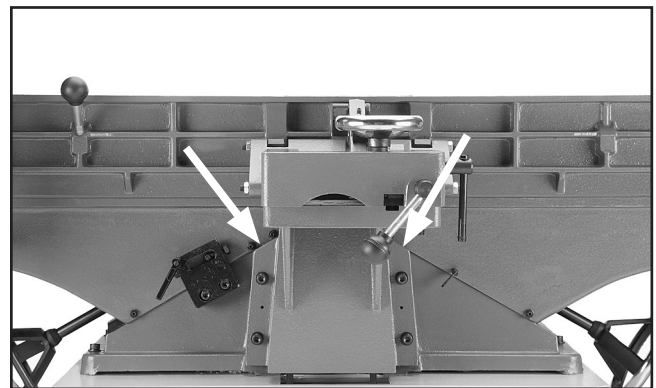

**Figure 47.** Location to lubricate gibs.



**Fence:** Place one or two drops of light machine oil on the fence pivot points (**Figure 48**) as needed.

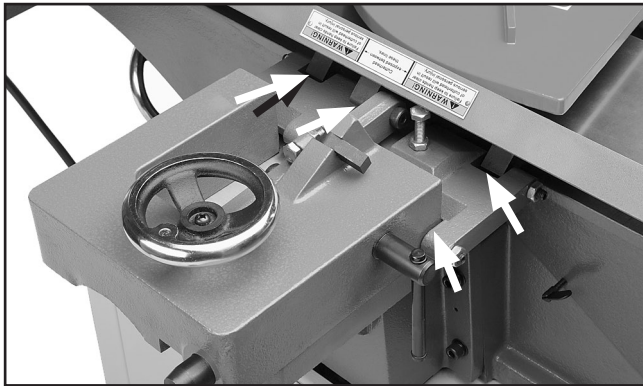

**Figure 48.** Fence lubrication locations.

## Cleaning

Vacuum excess wood chips and sawdust, and wipe off the remaining dust with a dry cloth—this ensures moisture from wood dust does not remain on bare metal surfaces. Treat all unpainted cast iron and steel with a non-staining lubricant after cleaning. We recommend products like SLIPIT®, G96® Gun Treatment, or Boeshield® T-9 (see **Page 28** for more details).

## V-Belts

V-belt removal and replacement involves removing the V-belt, rolling it off of the pulleys, replacing it with a new belt, then retensioning it.

Consider replacing the stock belt with Power Twist V-belts (see **Page 27**) to reduce vibration and noise, and increase belt lifespan.

### To adjust/replace the V-belt:

1. DISCONNECT JOINTER FROM POWER SOURCE!
2. Remove the rear access panel.
3. Using a 13mm wrench, loosen the motor bracket fasteners shown in **Figure 49**, raise the motor to remove the V-belt tension. It may help to use a 2x4 to lift the motor.

**Note:** *DO NOT* completely remove the motor mount bolts.

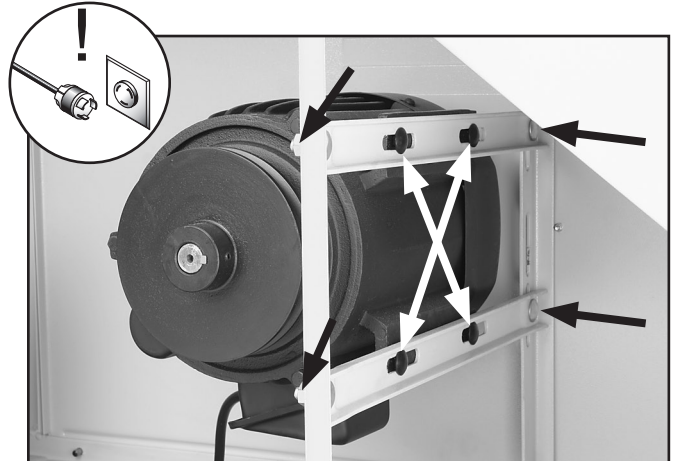

**Figure 49.** Motor bracket fasteners (black arrows); motor mount fasteners (white arrows).

4. Remove the V-belt and replace it with a new one.
5. Lower the motor and adjust the V-belt tension as needed so there is approximately  $\frac{1}{4}$ " deflection when the V-belts are pushed with moderate pressure as shown in **Figure 50**.

**Note:** *After the first 16 hours of belt life, retension the belts, as they will stretch and seat during this time.*

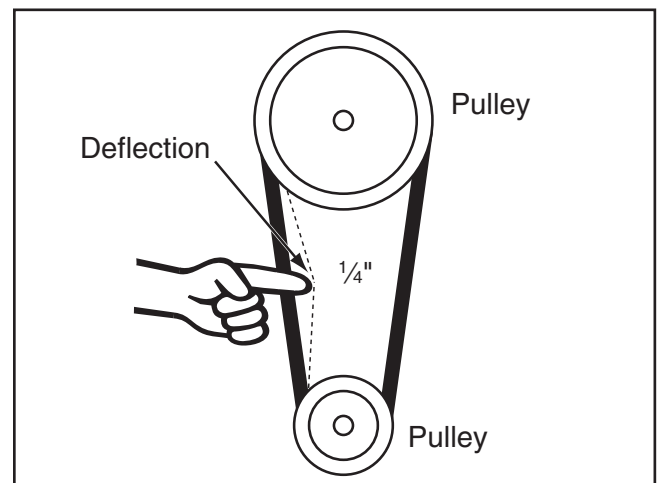

**Figure 50.** Checking V-belt tension.

6. Tighten the motor bracket fasteners and replace the rear access panel.





# SECTION 7: SERVICE

Review the troubleshooting and procedures in this section to fix or adjust your machine if a problem develops. If you need replacement parts or you are unsure of your repair skills, then feel free to call our Technical Support at (570) 546-9663.

## Troubleshooting

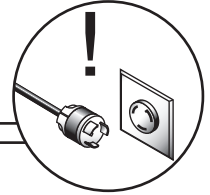

### Motor & Electrical

Symptom	Possible Cause	Possible Solution
Motor does not start or a breaker trips.	<ol style="list-style-type: none"> <li>1. OFF button has not been reset.</li> <li>2. Power supply switched OFF or is at fault.</li> <li>3. Plug/receptacle is at fault or wired incorrectly.</li> <li>4. Start capacitor is at fault.</li> <li>5. Motor connection wired incorrectly.</li> <li>6. Wall fuse/circuit breaker is blown/tripped.</li> <li>7. Wiring is open/has high resistance.</li> <li>8. Motor ON button or ON/OFF switch is at fault.</li> <li>9. Centrifugal switch is at fault.</li> <li>10. Motor is at fault.</li> </ol>	<ol style="list-style-type: none"> <li>1. Lift paddle and press OFF button down completely until it clicks. Press ON button in completely.</li> <li>2. Ensure power supply is switch on; ensure power supply has the correct voltage.</li> <li>3. Test for good contacts; correct the wiring.</li> <li>4. Test/replace if faulty.</li> <li>5. Correct motor wiring connections.</li> <li>6. Ensure circuit size is suitable for this machine; replace weak breaker.</li> <li>7. Check for broken wires or disconnected/corroded connections, and repair/replace as necessary.</li> <li>8. Replace faulty ON button or ON/OFF switch.</li> <li>9. Adjust/replace the centrifugal switch if available.</li> <li>10. Test/repair/replace.</li> </ol>
Motor stalls or is overloaded.	<ol style="list-style-type: none"> <li>1. Workpiece material is not suitable for this machine.</li> <li>2. Run capacitor is at fault.</li> <li>3. Belt slipping.</li> <li>4. Motor connection is wired incorrectly.</li> <li>5. Plug/receptacle is at fault.</li> <li>6. Pulley/sprocket slipping on shaft.</li> <li>7. Motor bearings are at fault.</li> <li>8. Machine is undersized for the task.</li> <li>9. Motor has overheated.</li> <li>10. Motor is at fault.</li> <li>11. Centrifugal switch is at fault.</li> </ol>	<ol style="list-style-type: none"> <li>1. Only cut wood products; make sure moisture content is below 20% and there are no foreign materials in the workpiece.</li> <li>2. Test/repair/replace.</li> <li>3. Replace bad belt, align pulleys, and re-tension.</li> <li>4. Correct motor wiring connections.</li> <li>5. Test for good contacts; correct the wiring.</li> <li>6. Replace loose pulley/shaft.</li> <li>7. Test by rotating shaft; rotational grinding/loose shaft requires bearing replacement.</li> <li>8. Use sharp knives; reduce feed rate/depth of cut.</li> <li>9. Clean off motor, let cool, and reduce workload.</li> <li>10. Test/repair/replace.</li> <li>11. Adjust/replace centrifugal switch if available.</li> </ol>
Machine has vibration or noisy operation.	<ol style="list-style-type: none"> <li>1. Motor or component is loose.</li> <li>2. Knives/gibs are at fault.</li> <li>3. V-belt worn or loose.</li> <li>4. Pulley is loose.</li> </ol>	<ol style="list-style-type: none"> <li>1. Inspect/replace stripped or damaged bolts/nuts, and re-tighten with thread locking fluid.</li> <li>2. Resharpen/replace knives as required; set knife alignment/protrusion correctly (<b>Page 34</b>).</li> <li>3. Inspect/replace belt with a new one (refer to <b>Page 31</b>).</li> <li>4. Realign/replace shaft, pulley, set screw, and key as required.</li> </ol>



## Motor & Electrical Continued

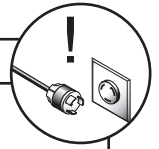

Symptom	Possible Cause	Possible Solution
Machine has vibration or noisy operation.	<ol style="list-style-type: none"> <li>5. Motor mount loose/broken.</li> <li>6. Machine is incorrectly mounted or sits unevenly.</li> <li>7. Motor fan is rubbing on fan cover.</li> <li>8. Motor bearings are at fault.</li> <li>9. Cutterhead bearings at fault.</li> <li>10. Centrifugal switch loose.</li> </ol>	<ol style="list-style-type: none"> <li>5. Tighten/replace.</li> <li>6. Relocate machine.</li> <li>7. Replace dented fan cover; replace loose/damaged fan.</li> <li>8. Test by rotating shaft; rotational grinding/loose shaft requires motor replacement.</li> <li>9. Replace bearing(s)/realign cutterhead.</li> <li>10. Replace.</li> </ol>

## Table

Symptom	Possible Cause	Possible Solution
Tables are hard to adjust.	<ol style="list-style-type: none"> <li>1. Table lock is engaged or partially engaged.</li> <li>2. Infeed table stops blocking movement.</li> </ol>	<ol style="list-style-type: none"> <li>1. Completely loosen the table lock.</li> <li>2. Loosen/reset infeed table positive stops.</li> </ol>

## Cutting

Symptom	Possible Cause	Possible Solution
Excessive snipe (gouge in the end of the board that is uneven with the rest of the cut).	<ol style="list-style-type: none"> <li>1. Outfeed table is set too low.</li> <li>2. Operator pushing down on trailing end of the workpiece.</li> </ol>	<ol style="list-style-type: none"> <li>1. Align outfeed table with cutterhead knife at top dead center (<b>Page 17</b>).</li> <li>2. Reduce/eliminate downward pressure on that end of workpiece.</li> </ol>
Workpiece stops in the middle of the cut.	<ol style="list-style-type: none"> <li>1. Outfeed table is set too high.</li> </ol>	<ol style="list-style-type: none"> <li>1. Align outfeed table with cutterhead knife at top dead center (<b>Page 17</b>).</li> </ol>
Chipping.	<ol style="list-style-type: none"> <li>1. Knots or conflicting grain direction in wood.</li> <li>2. Nicked or chipped blades.</li> <li>3. Feeding workpiece too fast.</li> <li>4. Taking too deep of a cut.</li> </ol>	<ol style="list-style-type: none"> <li>1. Inspect workpiece for knots and grain (<b>Page 21</b>); only use clean stock.</li> <li>2. Adjust one of the nicked knives sideways; replace knives (<b>Page 34</b>).</li> <li>3. Slow down the feed rate.</li> <li>4. Take a smaller depth of cut. (Always reduce cutting depth when surface planing or working with hard woods.)</li> </ol>
Fuzzy Grain.	<ol style="list-style-type: none"> <li>1. Wood may have high moisture content or surface wetness.</li> <li>2. Dull knives.</li> </ol>	<ol style="list-style-type: none"> <li>1. Check to make sure moisture content is less than 20% and allow to dry if moisture is too high.</li> <li>2. Sharpen or replace knives (<b>Page 34</b>).</li> </ol>
Long lines or ridges that run along the length of the board	<ol style="list-style-type: none"> <li>1. Nicked or chipped knives.</li> </ol>	<ol style="list-style-type: none"> <li>1. Adjust one of the nicked knives sideways; replace knives (<b>Page 34</b>).</li> </ol>
Uneven cutter marks, wavy surface, or chatter marks across the face of the board.	<ol style="list-style-type: none"> <li>1. Feeding workpiece too fast.</li> <li>2. Knives not adjusted at even heights in the cutterhead.</li> </ol>	<ol style="list-style-type: none"> <li>1. Slow down the feed rate.</li> <li>2. Adjust the knives so they are set up evenly in the cutterhead (<b>Page 34</b>).</li> </ol>
Board edge is concave or convex after jointing.	<ol style="list-style-type: none"> <li>1. Board not held with even pressure on infeed and outfeed table during cut.</li> <li>2. Board started too uneven.</li> </ol>	<ol style="list-style-type: none"> <li>1. Hold board with even pressure as it moves over the cutterhead.</li> <li>2. Take partial cuts to remove the extreme high spots before doing a full pass.</li> </ol>



# Inspecting Knives

The height of the knives can be easily and quickly inspected with the knife setting gauge. This inspection will ensure that the knives are set to the correct height in the cutterhead.

Tools Needed	Qty
Knife Setting Gauge .....	1

## To inspect the knives:

1. DISCONNECT JOINTER FROM POWER SOURCE!
2. Remove the cutterhead guard or block it out of the way.
3. Lower the infeed table to the 1/2" scale mark and lower the outfeed table as needed.
4. Place the knife gauge on the cutterhead, directly over a knife, as shown in **Figure 51**.

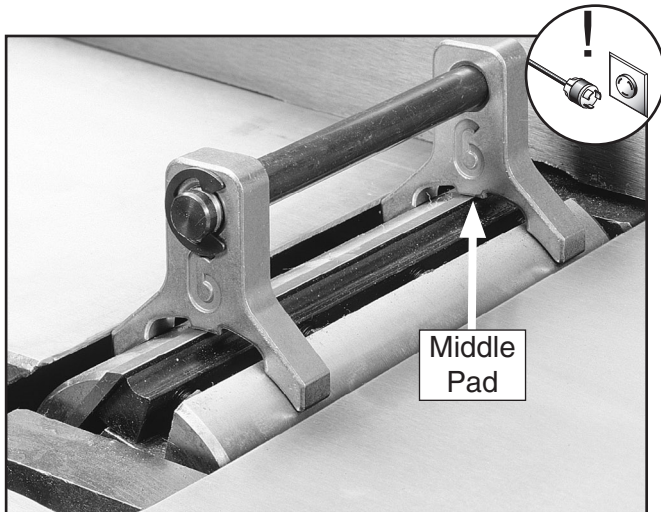

**Figure 51.** Gauge positioned over cutterhead knife.

5. Carefully inspect how the gauge touches the cutterhead and the knife.

—If both outside legs of the gauge sit firmly on the cutterhead and the middle pad just touches the knife, then that knife is set correctly. (Repeat this inspection with the other knives.)

—If the gauge does not sit firmly on the cutterhead and touch the knife edge as described, then reset that knife. (Repeat this inspection with the other knives before resetting.)

# Setting/Replacing Knives

Setting the knives correctly is crucial to the proper operation of the jointer and is very important in keeping the knives sharp. If one knife is higher than the others, it will do the majority of the work, and thus, dull much faster than the others.

The knife gauge included with the jointer is designed to set the knives at 0.063" (1/16"), which is the correct distance all the knives should protrude above the cutterhead.

The Model G0656 comes with jack screws for cutterhead adjustments (see **Figure 52**).

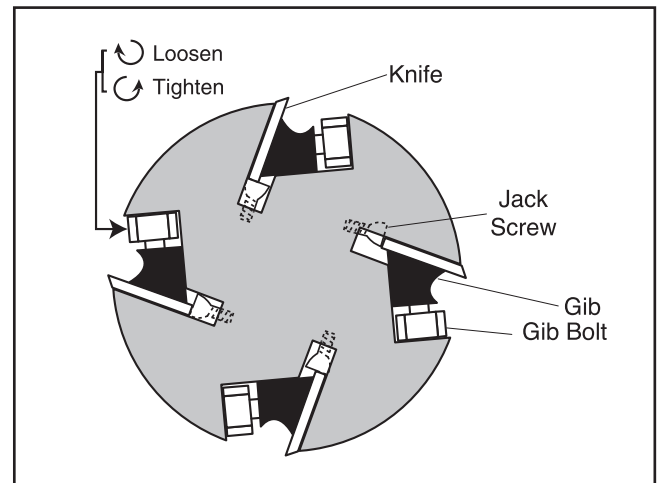

**Figure 52.** Cutterhead profile diagram.

Tools Needed	Qty
Knife Setting Gauge .....	1
Hex Wrench 2.5mm.....	1
Wrench 8mm .....	1

## To set or replace the knives:

1. DISCONNECT JOINTER FROM POWER SOURCE!



2. Remove the cutterhead guard from the table and lower the infeed and outfeed tables as far as they go. This will give you unrestricted access to the cutterhead.

3. Remove the rear access panel to expose the cutterhead pulley.

4. Rotate the cutterhead pulley to give you good access to one of the cutterhead knives.

5. Loosen the cutterhead gib bolts, starting in the middle, and alternating back and forth until all of the gib bolts are loose, but not falling out.

—If this is the first time you are setting the knives, or if you are replacing them, remove a gib and knife from the cutterhead. Clean the gib and clean inside the cutterhead slot to remove all pitch or sawdust. Coat the knife and gib with a metal protectant (**Page 28**)

6. Position the knife gauge over the knife as shown in **Figure 51** and loosen the gib bolts until the knife is completely loose.

7. Using a 2.5mm hex wrench, find the jack screws through the access holes in the cutterhead (**Figure 53**) and rotate the jack screws to raise or lower the knife. When the knife is set correctly, it will barely touch the middle pad of the knife setting jig. Snug the gib bolts tight enough to just hold the knife in place. Repeat **Steps 5-7** with the rest of the knives.

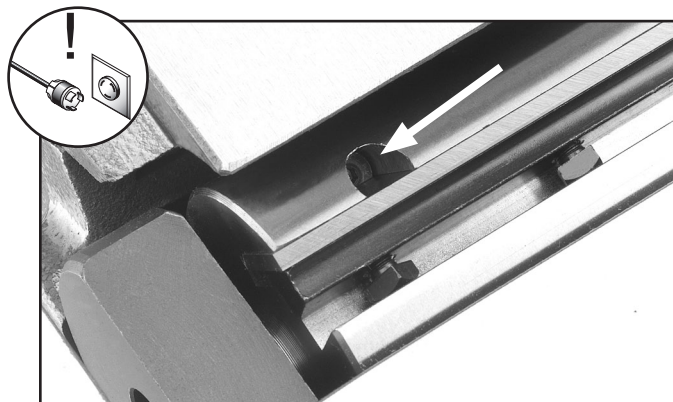

**Figure 53.** Jack screw access hole.

8. Rotate the cutterhead to the first knife you started with. Slightly tighten all the gib bolts, starting at the middle and working your way to the ends by alternating left and right (**Figure 54**). Repeat this step on the rest of the knives.

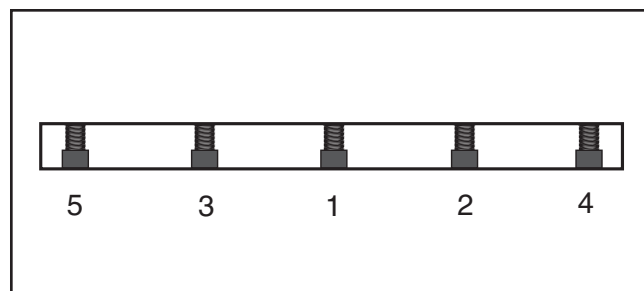

**Figure 54.** Gib bolt tightening sequence.

9. Repeat **Step 8**, but final tighten each gib bolt.

10. Adjust the outfeed table to match the new knife heights (refer to **Setting Outfeed Table Height, Page 17**).

11. Replace the cutterhead guard and the rear access panel.



# Setting Infeed Table

The infeed table height is set by calibrating the depth scale, and adjusting the positive stop bolts and depth stop lever.

Tools Needed	Qty
Straightedge .....	1
Phillips Head Screwdriver .....	1
Wrench 14mm .....	1
Hex Wrench 4mm.....	1

## Calibrating Depth Scale

The depth scale on the infeed table can be calibrated or "zeroed" if it is not correct.

1. Set the outfeed table height as described in **Setting Outfeed Table Height** on **Page 17**.
2. Move the cutterhead guard out of the way.
3. Loosen the jam nut on the top height positive stop bolt (**Figure 55**) and raise the bolt so it does not obstruct the infeed table when it is raised in **Step 5**.

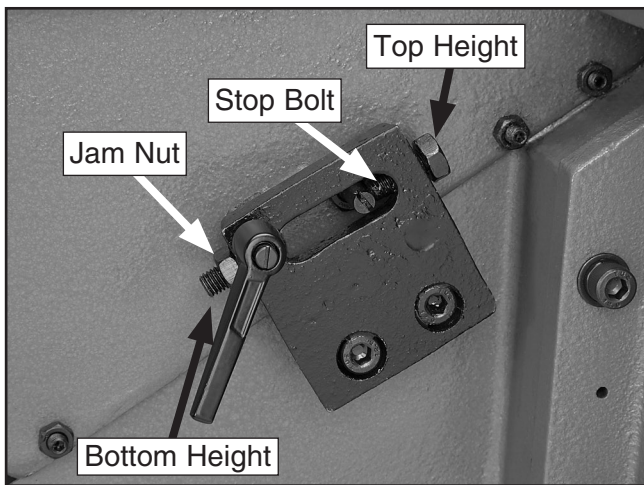

**Figure 55.** Positive stop bolts for infeed table.

4. Place a straightedge across the infeed and outfeed tables.
5. Adjust the infeed table until it is level with the outfeed table, as illustrated in **Figure 56**.

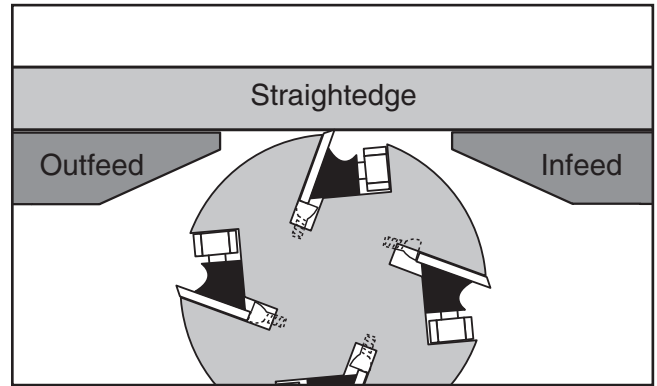

**Figure 56.** Infeed table adjusted even with outfeed table.

6. Using a screwdriver, adjust the scale pointer exactly to "0", as shown in **Figure 57**.

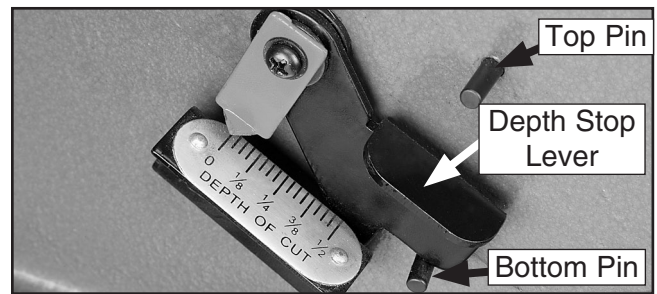

**Figure 57.** Depth stop lever set at "0".

## Positive Stop Bolts

The infeed table has positive stop bolts that allow the operator to quickly adjust the infeed table between finish/final cuts and shaping/heavy cuts.

We recommend setting the minimum depth of cut to  $\frac{1}{32}$ " and the maximum depth of cut to  $\frac{1}{8}$ " for most operations. **DO NOT exceed  $\frac{1}{8}$ " cut per pass on this machine or kickback and serious injury may occur!**

Each positive stop bolt (**Figure 55**) controls the top or bottom range of the table movement. The jam nuts lock the positive stop bolt in position so it won't move during operation.

## Depth Stop Lever

A depth stop lever (**Figure 57**) above the depth scale allows the operator to set the maximum depth of cut to  $\frac{1}{8}$ ".

To engage the lever, position it as shown in **Figure 57**. To disengage the lever, raise the table to "0", then raise and hold the lever against the top pin while lowering the table to the desired height.





# Setting Fence Stops

The fence stops simplify the task of adjusting the fence to 45° inward, 90°, and 45° outward (135°).

Tools Needed	Qty
45° Square .....	1
90° Square .....	1
Sliding Bevel.....	1
Wrench 14mm.....	1
Hex Wrench 3mm.....	1

## To set the 45° inward fence stop:

- Using a 45° square, adjust the fence to the 45° inward position, as shown in **Figure 58**.

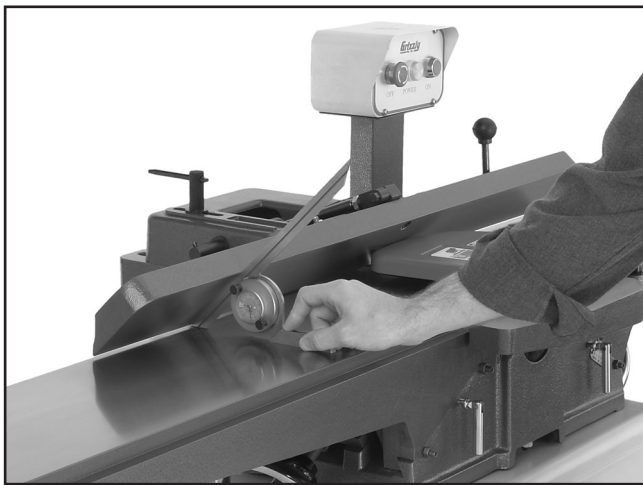

**Figure 58.** Example of adjusting fence 45° inward.

- Loosen the jam nut shown in **Figure 59**.

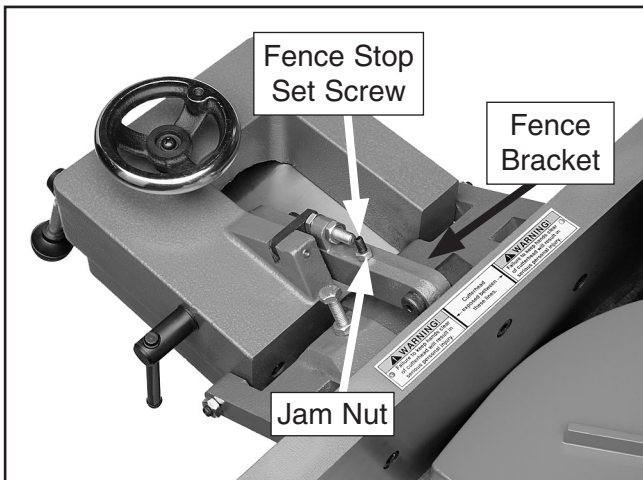
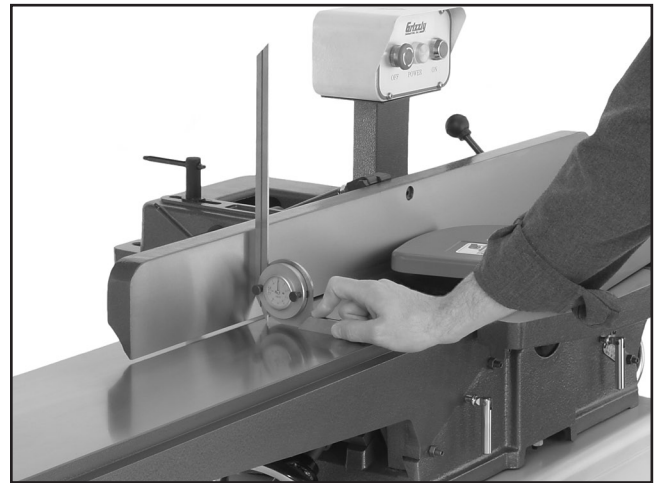

**Figure 59.** 45° inward fence stop set screw.

- Adjust the 45° inward fence stop set screw until it makes contact with the back of the fence bracket.
- Retighten the jam nut loosened in **Step 2**.

## To set the 90° fence stop:

- Using a 90° square, adjust the fence to the 90° position, as shown in **Figure 60**.



**Figure 60.** Example of adjusting fence to 90°.

- Flip the 90° swing stop into the position shown in **Figure 61**.

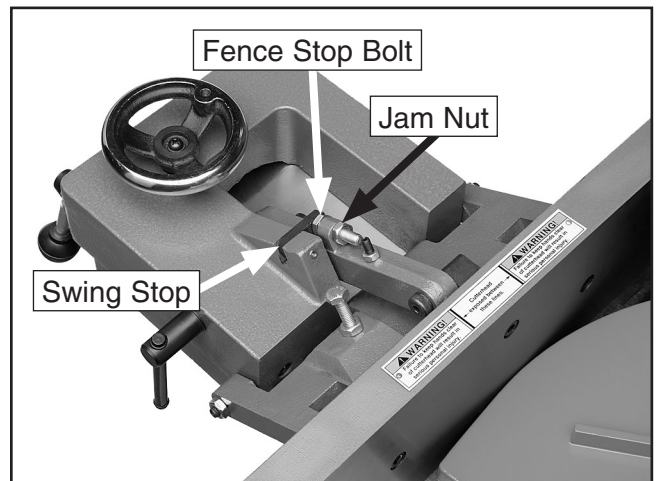

**Figure 61.** 90° swing stop engaged.

- Loosen the jam nut on the 90° fence stop bolt (**Figure 61**).
- Adjust the 90° fence stop bolt until it makes contact with the 90° swing stop.
- Retighten the jam nut loosened in **Step 3**.



**To set the 45° outward fence stop:**

1. Disengage the swing stop (see **Figure 23** on **Page 20**).
2. Using a sliding bevel adjusted to 135°, adjust the fence to the 135° (45° outward) position, as shown in **Figure 62**.



**Figure 62.** Example of adjusting fence 45° outward.

3. Loosen the jam nut on the 45° outward fence stop bolt (**Figure 63**).

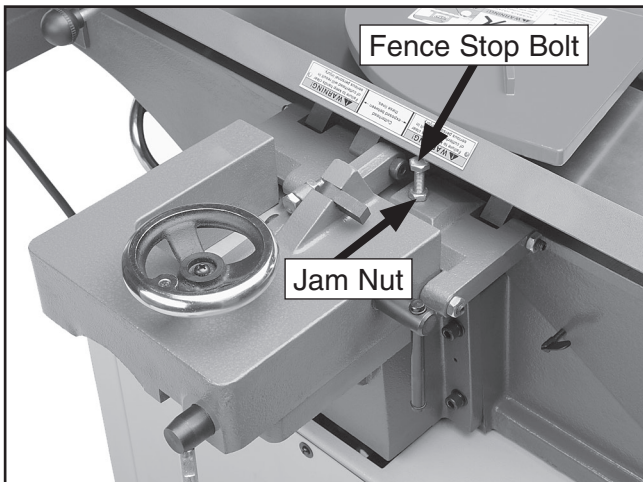

**Figure 63.** 45° outward fence stop bolt.

4. Adjust the 45° outward fence stop bolt until it makes contact with the back of the fence.
5. Retighten the jam nut loosened in **Step 3**.

# Adjusting Gibs

The function of the table gibs is to eliminate excessive play in the table movement. The gibs also control how easy it will be to move the tables up and down.

<b>Tools Needed</b>	<b>Qty</b>
Wrench 10mm .....	1
Hex Wrench 3mm.....	1

**To adjust the table gibs:**

1. Using a 10mm wrench, loosen the three infeed table gib nuts on the back of the jointer base (**Figure 64**).

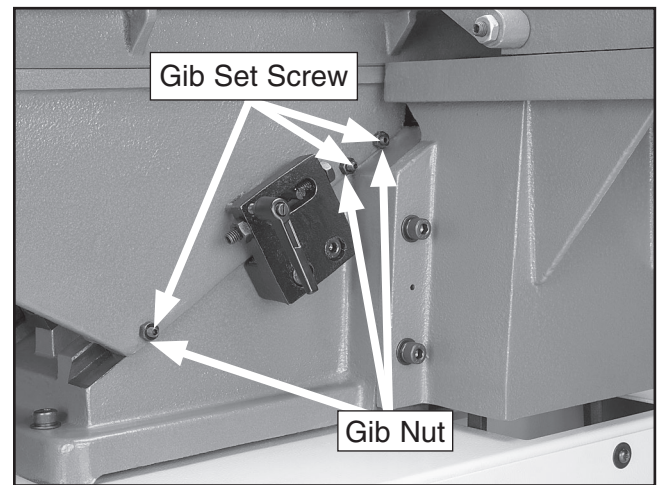

**Figure 64.** Infeed table gib controls.

2. Oil the gibs and table leadscrew if needed (see **Page 30**).
3. Using a 3mm hex wrench, evenly tighten the gib set screws a small amount, then check the table by moving it up and down. Adjust the set screws as needed until the friction of the table movement is balanced between minimal play and ease of movement.

**Note:** *Tighter gibs reduce play but make it harder to adjust the tables.*

4. Repeat **Steps 1-3** with the outfeed table.
5. Set the outfeed table height as described in **Setting Outfeed Table Height** on **Page 17**.





# Wiring Diagram



COLOR KEY	
BLACK	(Bk)
WHITE	(Wt)
GREEN	(Gn)
RED	(Rd)

**NOTICE**  
The motor wiring shown here is current at the time of printing, but it may not match your machine. Always use the wiring diagram inside the motor junction box.



View this page in color at [www.grizzly.com](http://www.grizzly.com).

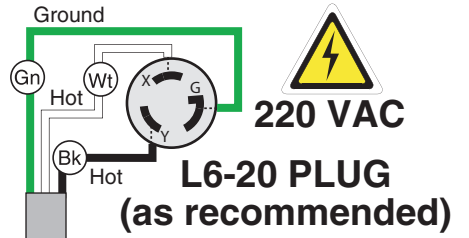

PUSH BUTTON SWITCH  
(viewed from behind)

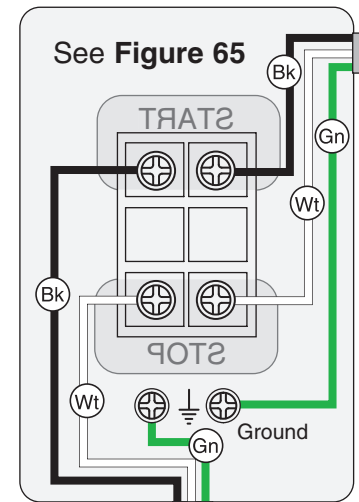

Figure 65. Switch wiring.

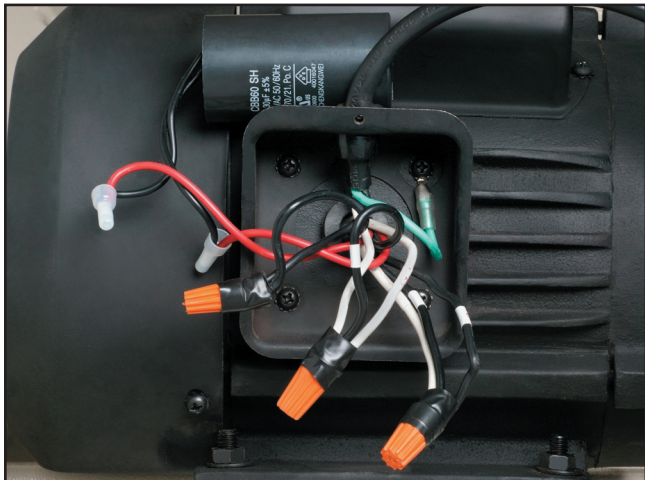
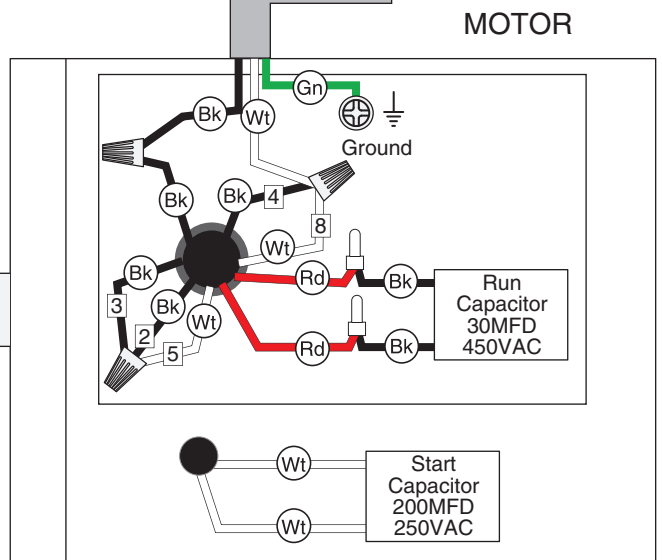

Figure 66. Motor junction box and capacitor wiring.



See Figure 66



# Table Parts Breakdown

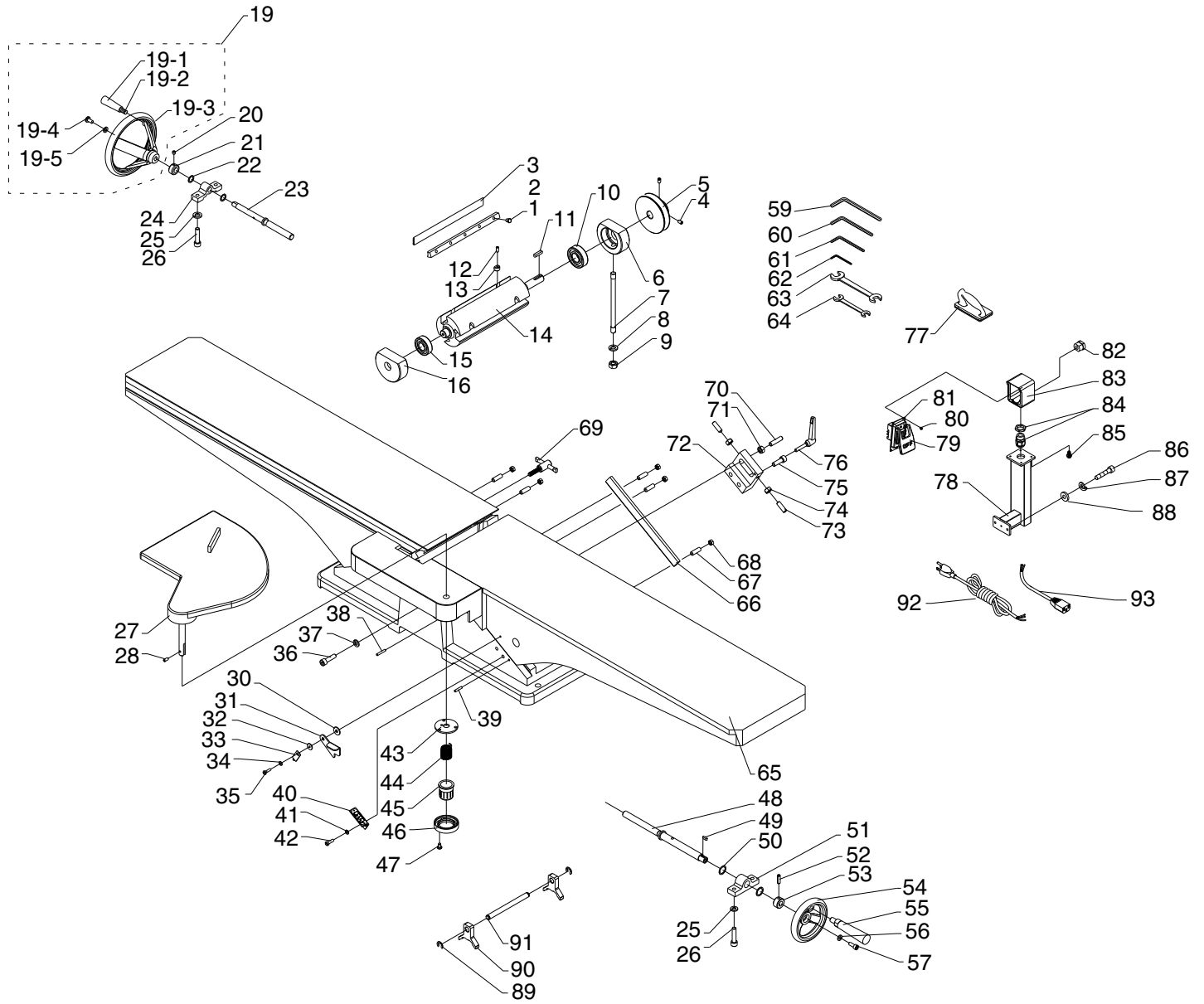

# Table Parts List

REF	PART #	DESCRIPTION
1	P0656001	GIB BOLT
2	P0656002	GIB
3	P0656003	KNIFE
4	PSS01M	SET SCREW M6-1 X 10
5	P0656005	PULLEY
6	P0656006	RIGHT BEARING SUPPORT BLOCK
7	P0656007	STUD
8	PLW06M	LOCK WASHER 10MM
9	PN02M	HEX NUT M10-1.5
10	P6204	BALL BEARING 6204ZZ
11	PK12M	KEY 5 X 5 X 30
12	PSS53M	SET SCREW M5-.8 X 12
13	P0656013	SPECIAL NUT
14	P0656014	CUTTERHEAD
15	P6203	BALL BEARING 6203ZZ
16	P0656016	LEFT BEARING SUPPORT BLOCK
19	P0656019	HANDWHEEL ASSY
19-1	P0656019-1	HANDLE
19-2	P0656019-2	SHOULDER SCREW
19-3	P0656019-3	HANDWHEEL
19-4	PSB26M	CAP SCREW M6-1 X 12
19-5	PW03M	FLAT WASHER 6MM
20	PSS02M	SET SCREW M6-1 X 6
21	P0656021	COLLAR
22	P0656022	SPECIAL FLAT WASHER
23	P0656023	SCREW SHAFT
24	P0656024	BLOCK
25	PLW04M	LOCK WASHER 8MM
26	PSB40M	CAP SCREW M8-1.25 X 35
27	P0656027	CUTTERHEAD GUARD
28	PSS53M	SET SCREW M5-.8 X 12
30	P0656030	SPACER
31	P0656031	STOP LEVER
32	PW05M	FLAT WASHER 4MM
33	P0656033	POINTER
34	PW05M	FLAT WASHER 4MM
35	PS21M	PHLP HD SCR M4-.7 X 15
36	PSB40M	CAP SCREW M8-1.25 X 35
37	PLW04M	LOCK WASHER 8MM
38	PRP56M	ROLL PIN 4 X 25
39	P0656039	ALIGNMENT PIN 4 X 20
40	P0656040	DEPTH SCALE
41	PLW01M	LOCK WASHER 5MM
42	PSB24M	CAP SCREW M5-.8 X 16
43	P0656043	PLATE
44	P0656044	TORSION SPRING
45	P0656045	CUP

REF	PART #	DESCRIPTION
46	P0656046	RETAINER
47	PSB53M	CAP SCREW M5-.8 X 18
48	P0656048	SCREW SHAFT
49	PK69M	KEY 4 X 4 X 12
50	P0656050	SPACER
51	P0656051	BLOCK
52	PRP49M	ROLL PIN 5 X 25
53	P0656053	COLLAR
54	P0656054	HANDWHEEL
55	P0656055	HANDLE
56	P0656056	SPECIAL FLAT WASHER
57	PSB26M	CAP SCREW M6-1 X 12
59	PAW06M	HEX WRENCH 6MM
60	PAW04M	HEX WRENCH 4MM
61	PAW03M	HEX WRENCH 3MM
62	PAW02.5M	HEX WRENCH 2.5MM
63	PWR1214	WRENCH 12 X 14
64	PWR810	WRENCH 8 X 10
65	P0656065	TABLE ASSY
66	P0656066	GIB
67	PSS12M	SET SCREW M6-1 X 25
68	PN01M	HEX NUT M6-1
69	P0656069	OUTFEED TABLE LOCK M6-1 X 25
70	P0656070	SPECIAL SCREW
71	PN01M	HEX NUT M6-1
72	P0656072	STOP BLOCK
73	PSS21M	SET SCREW M8-1.25 X 25
74	PN03M	HEX NUT M8-1.25
75	PSB31M	CAP SCREW M8-1.25 X 25
76	P0656076	INFEED LOCK LEVER M6-1 X 30
77	P0656077	JOINTER PUSH BLOCK
78	P0656078	SWITCH PEDESTAL
79	P0656079	SWITCH PADDLE
80	PSB18M	CAP SCREW M4-.7 X 8
81	P0656081	SWITCH BRACKET
82	P0656082	STRAIN RELIEF
83	P0656083	SWITCH BOX
84	P0656084	STRAIN RELIEF
85	PFB17M	FLANGE BOLT M6-1 X 16
86	PSB31M	CAP SCREW M8-1.25 X 25
87	PLW04M	LOCK WASHER 8MM
88	PW01M	FLAT WASHER 8MM
89	PR39M	EXT RETAINING RING 8MM
90	P0656090	KNIFE GAUGE BLOCK
91	P0656091	KNIFE GAUGE ROD
92	P0656092	POWER CORD 14AWG X 3C
93	P0656093	SWITCH CORD 14AWG X 3C



# Fence Parts Breakdown

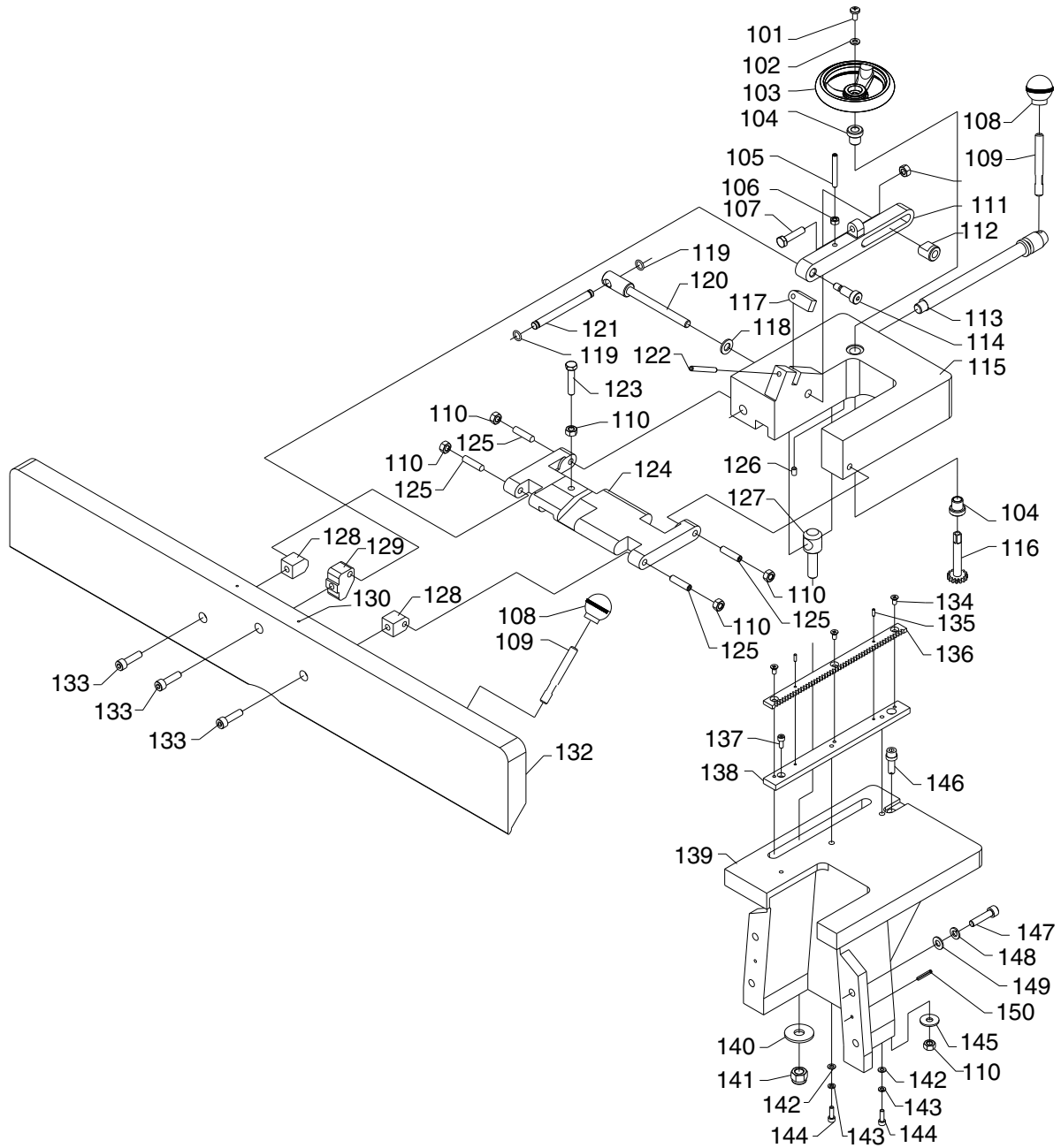

# Fence Parts List

REF	PART #	DESCRIPTION
101	PS14M	PHLP HD SCR M6-1 X 12
102	PW03M	FLAT WASHER 6MM
103	P0656103	HANDWHEEL
104	P0656104	BUSHING
105	PSS85M	SET SCREW M6-1 X 45
106	PN01M	HEX NUT M6-1
107	PB20M	HEX BOLT M8-1.25 X 35
108	P0656108	KNOB M10-1.5
109	P0656109	STUD M10-1.5
110	PN03M	HEX NUT M8-1.25
111	P0656111	CLAMP ARM
112	P0656112	LOCK NUT
113	P0656113	ECCENTRIC LOCK LEVER
114	P0656114	SPECIAL SCREW M10-1.5 X 20
115	P0656115	FENCE CARRIAGE
116	P0656116	GEAR
117	P0656117	90 DEG STOP BLOCK
118	PW04M	FLAT WASHER 10MM
119	POR0010	O-RING 10 X 2
120	P0656120	TILT LOCK SHAFT
121	P0656121	TILT LOCK HANDLE
122	P0656122	ALIGNMENT PIN 6 X 50
123	PB15M	HEX BOLT M8-1.25 X 40
124	P0656124	BRACKET
125	PSS74M	SET SCREW M8-1.25 X 35

REF	PART #	DESCRIPTION
126	PSS01M	SET SCREW M6-1 X 10
127	P0656127	ADJUST LEVER
128	P0656128	SMALL BRACKET BLOCK
129	P0656129	BRACKET BLOCK
130	P0656130	RIVET 2 X 4
132	P0656132	FENCE
133	PSB13M	CAP SCREW M8-1.25 X 30
134	PFH07M	FLAT HD SCR M5-.8 X 10
135	PRP44M	ROLL PIN 3 X 10
136	P0656136	RACK
137	PSB20M	CAP SCREW M5-.8 X 14
138	P0656138	GIB
139	P0656139	FENCE SUPPORT
140	PW06M	FLAT WASHER 12MM
141	P0656141	SPECIAL HEX NUT M12-1.75
142	PW02M	FLAT WASHER 5MM
143	PLW01M	LOCK WASHER 5MM
144	PSB53M	CAP SCREW M5-.8 X 18
145	P0656145	SPECIAL FLAT WASHER
146	P0656146	ECCENTRIC STUD
147	PSB40M	CAP SCREW M8-1.25 X 35
148	PLW04M	LOCK WASHER 8MM
149	PW01M	FLAT WASHER 8MM
150	PRP49M	ROLL PIN 5 X 25





# Stand Parts Breakdown

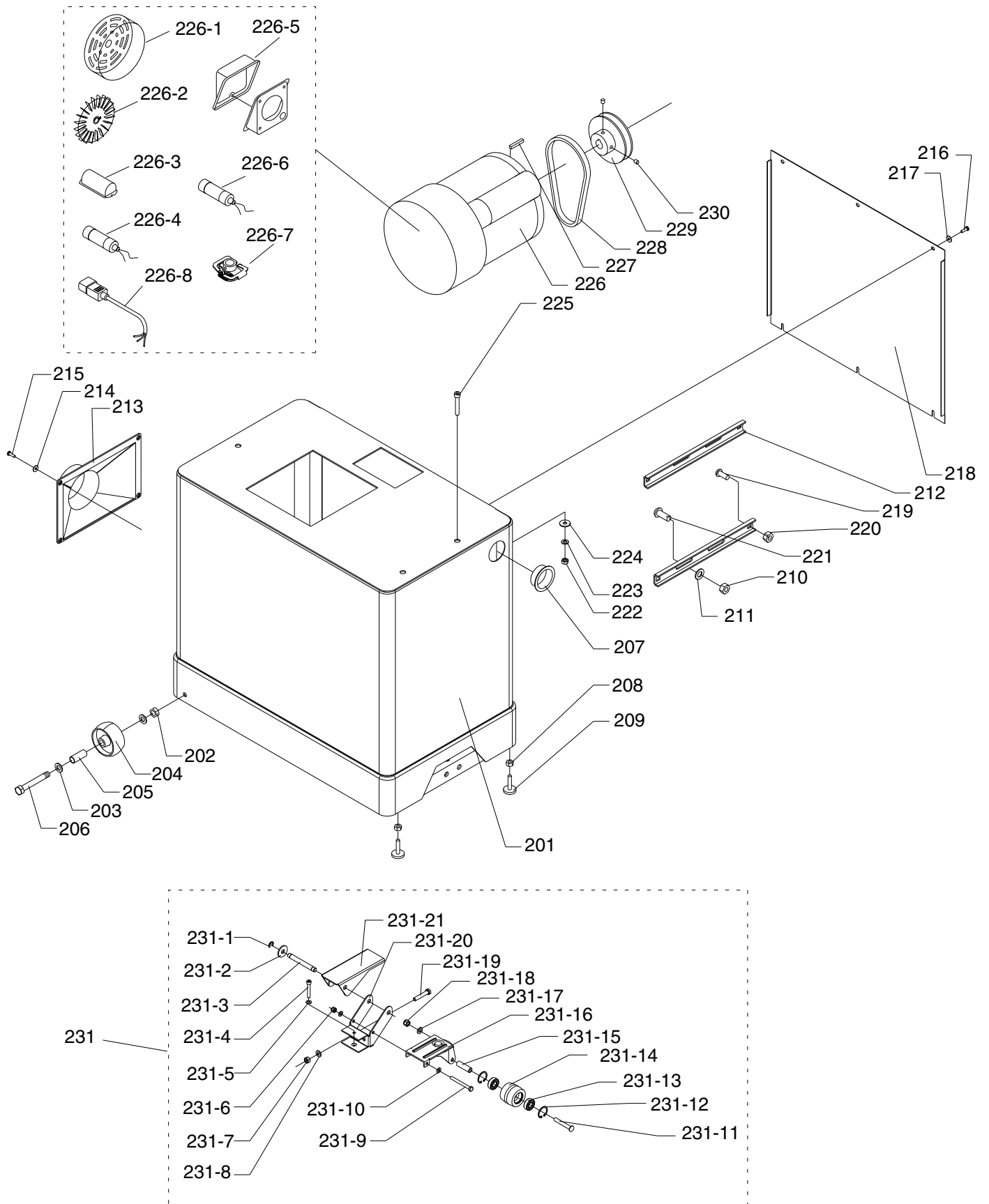

# Stand Parts List

REF	PART #	DESCRIPTION
201	P0656201	CABINET
202	PLN04M	LOCK NUT M8-1.25
203	PW01M	FLAT WASHER 8MM
204	P0656204	WHEEL
205	P0656205	SLEEVE
206	PB86M	HEX BOLT M8-1.25 X 65
207	P0656207	PLASTIC GROMMET
208	PN08	HEX NUT 3/8-16
209	P0656209	ADJUSTING SCREW
210	PN02	HEX NUT 5/16-18
211	PW07	FLAT WASHER 5/16
212	P0656212	MOTOR BRACKET
213	P0656213	DUST PORT
214	PW02M	FLAT WASHER 5MM
215	PS40M	PHLP HD SCR M5-.8 X 16
216	PS40M	PHLP HD SCR M5-.8 X 16
217	PW02M	FLAT WASHER 5MM
218	P0656218	CABINET REAR COVER
219	PCB05	CARRIAGE BOLT 5/16-18 X 3/4
220	PN02	HEX NUT 5/16-18
221	PCB11	CARRIAGE BOLT 5/16-18 X 1
222	PN03M	HEX NUT M8-1.25
223	PLW04M	LOCK WASHER 8MM
224	PW01M	FLAT WASHER 8MM
225	PSB05M	CAP SCREW M8-1.25 X 50
226	P0656226	MOTOR 3PH 220V
226-1	P0656226-1	FAN COVER
226-2	P0656226-2	FAN
226-3	P0656226-3	R CAPACITOR COVER
226-4	P0656226-4	R CAP 30M 450V 2-3/4 X 1-1/2

REF	PART #	DESCRIPTION
226-5	P0656226-5	JUNCTION BOX
226-6	P0656226-6	S CAPACITOR 200M 250V 3-1/2 X 1-1/2
226-7	P0656226-7	CENTRIFUGAL SWITCH
226-8	P0656226-8	MOTOR CORD 14AWG X 3C
227	PK12M	KEY 5 X 5 X 30
228	PVA50	V-BELT A-50 4L500
229	P0656229	MOTOR PULLEY
230	PSS01M	SET SCREW M6-1 X 10
231	P0656231	PEDAL ASSEMBLY
231-1	PR16M	EXT RETAINING RING 9MM
231-2	P0656231-2	SPECIAL FLAT WASHER
231-3	P0656231-3	SHAFT
231-4	PB22M	HEX BOLT M8-1.25 X 50
231-5	PW01M	FLAT WASHER 8MM
231-6	P0656231-6	SPECIAL HEX NUT M8-1.25
231-7	PN02M	HEX NUT M10-1.5
231-8	PW04M	FLAT WASHER 10MM
231-9	PB45M	HEX BOLT M8-1.25 X 100
231-10	PW01M	FLAT WASHER 8MM
231-11	P0656231-11	SPECIAL BOLT
231-12	PR21M	INT RETAINING RING 35MM
231-13	P6202	BALL BEARING 6202ZZ
231-14	P0656231-14	TROLLEY WHEEL
231-15	P0656231-15	SLEEVE
231-16	P0656231-16	UNIVERSAL KIT TROLLEY
231-17	PW04M	FLAT WASHER 10MM
231-18	P0656231-18	SPECIAL HEX NUT M10
231-19	PB144M	HEX BOLT M10-1.5 X 55
231-20	P0656231-20	BRACKET
231-21	P0656231-21	PEDAL



# Label Placement

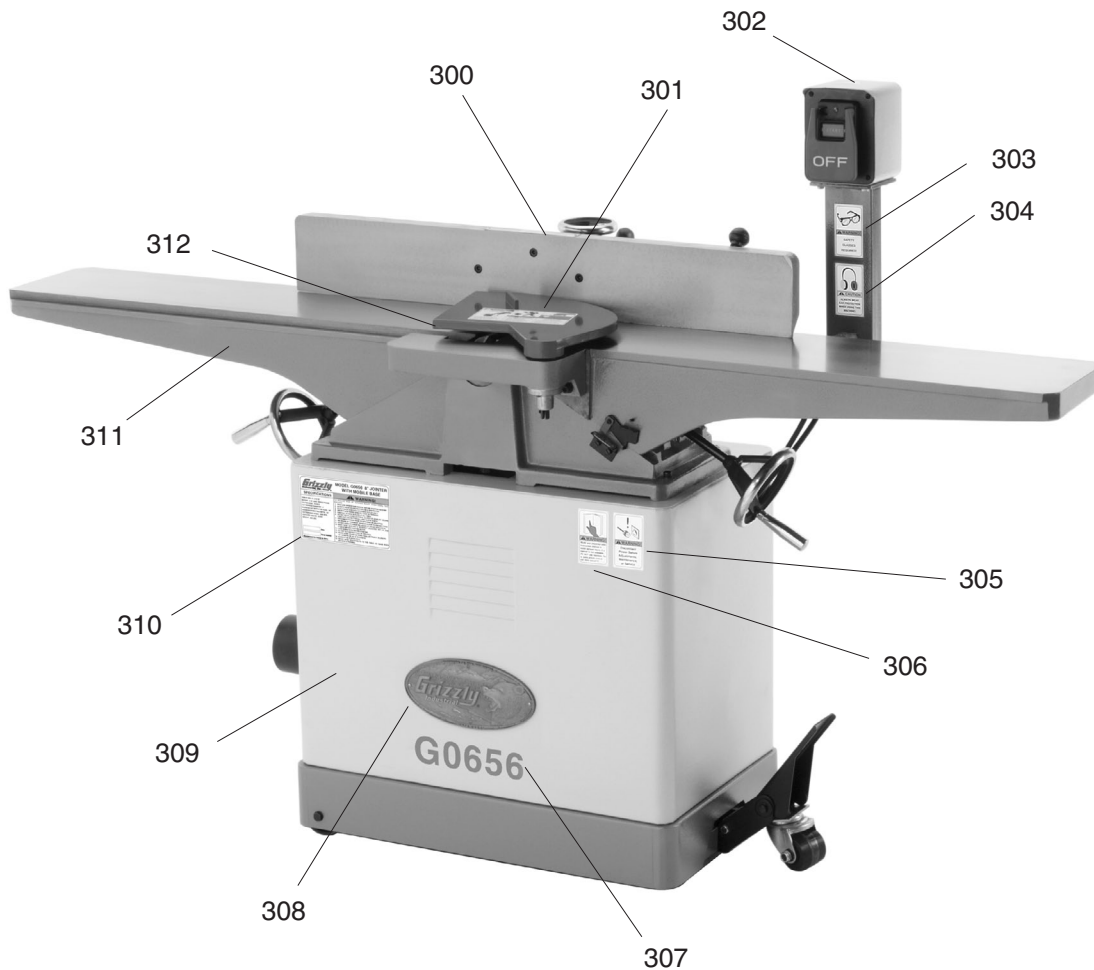

REF	PART #	DESCRIPTION
300	P0656300	FENCE/CUTTERHEAD LABEL
301	P0656301	CUTTTERHEAD GUARD LABEL
302	PLABEL-14	ELECTRICITY LABEL
303	PLABEL-11	SAFETY GLASSES 2" X 3 5/16"
304	PLABEL-15	EAR PROTECTION 2" X 3-5/16"H
305	P0656305	UNPLUG 220V POWER LABEL
306	PLABEL-12A	READ MANUAL-VERTICAL NS 7/05

REF	PART #	DESCRIPTION
307	P0656307	MODEL NUMBER LABEL
308	G8588	SMALL GRIZZLY NAMEPLATE
309	PPAINT-11	PUTTY TOUCH-UP PAINT
310	P0656310	MACHINE ID LABEL
311	P-PAINT1	GRIZZLY GREEN TOUCH-UP PAINT
312	P0656312	RED TOUCH-UP PAINT

## WARNING

Safety labels warn about machine hazards and ways to prevent injury. The owner of this machine **MUST** maintain the original location and readability of the labels on the machine. If any label is removed or becomes unreadable, **REPLACE** that label before using the machine again. Contact Grizzly at (800) 523-4777 or [www.grizzly.com](http://www.grizzly.com) to order new labels.





# WARRANTY CARD

Name \_\_\_\_\_

Street \_\_\_\_\_

City \_\_\_\_\_ State \_\_\_\_\_ Zip \_\_\_\_\_

Phone # \_\_\_\_\_ Email \_\_\_\_\_ Invoice # \_\_\_\_\_

Model # \_\_\_\_\_ Order # \_\_\_\_\_ Serial # \_\_\_\_\_

The following information is given on a voluntary basis. It will be used for marketing purposes to help us develop better products and services. **Of course, all information is strictly confidential.**

1. How did you learn about us?

- Advertisement
- Card Deck
- Friend
- Website
- Catalog
- Other:

2. Which of the following magazines do you subscribe to?

- |   |  |   |
|---|--|---|
| <input type="checkbox"/> Cabinet Maker          | <input type="checkbox"/> Popular Mechanics   | <input type="checkbox"/> Today's Homeowner    |
| <input type="checkbox"/> Family Handyman        | <input type="checkbox"/> Popular Science     | <input type="checkbox"/> Wood                 |
| <input type="checkbox"/> Hand Loader            | <input type="checkbox"/> Popular Woodworking | <input type="checkbox"/> Wooden Boat          |
| <input type="checkbox"/> Handy                  | <input type="checkbox"/> Practical Homeowner | <input type="checkbox"/> Woodshop News        |
| <input type="checkbox"/> Home Shop Machinist    | <input type="checkbox"/> Precision Shooter   | <input type="checkbox"/> Woodsmith            |
| <input type="checkbox"/> Journal of Light Cont. | <input type="checkbox"/> Projects in Metal   | <input type="checkbox"/> Woodwork             |
| <input type="checkbox"/> Live Steam             | <input type="checkbox"/> RC Modeler          | <input type="checkbox"/> Woodworker West      |
| <input type="checkbox"/> Model Airplane News    | <input type="checkbox"/> Rifle               | <input type="checkbox"/> Woodworker's Journal |
| <input type="checkbox"/> Modeltec               | <input type="checkbox"/> Shop Notes          | <input type="checkbox"/> Other:               |
| <input type="checkbox"/> Old House Journal      | <input type="checkbox"/> Shotgun News        |   |

3. What is your annual household income?

- \$20,000-\$29,000
- \$30,000-\$39,000
- \$40,000-\$49,000
- \$50,000-\$59,000
- \$60,000-\$69,000
- \$70,000+

4. What is your age group?

- 20-29
- 30-39
- 40-49
- 50-59
- 60-69
- 70+

5. How long have you been a woodworker/metalworker?

- 0-2 Years
- 2-8 Years
- 8-20 Years
- 20+ Years

6. How many of your machines or tools are Grizzly?

- 0-2
- 3-5
- 6-9
- 10+

7. Do you think your machine represents a good value?  Yes  No

8. Would you recommend Grizzly Industrial to a friend?  Yes  No

9. Would you allow us to use your name as a reference for Grizzly customers in your area?  
**Note:** We never use names more than 3 times.  Yes  No

10. Comments: \_\_\_\_\_

---



---



---

CUT ALONG DOTTED LINE

FOLD ALONG DOTTED LINE

\_\_\_\_\_  
\_\_\_\_\_  
\_\_\_\_\_



Place  
Stamp  
Here



**GRIZZLY INDUSTRIAL, INC.**  
P.O. BOX 2069  
BELLINGHAM, WA 98227-2069



FOLD ALONG DOTTED LINE

Send a Grizzly Catalog to a friend:

Name \_\_\_\_\_  
Street \_\_\_\_\_  
City \_\_\_\_\_ State \_\_\_\_\_ Zip \_\_\_\_\_

TAPE ALONG EDGES--PLEASE DO NOT STAPLE



# WARRANTY AND RETURNS

---

Grizzly Industrial, Inc. warrants every product it sells for a period of **1 year** to the original purchaser from the date of purchase. This warranty does not apply to defects due directly or indirectly to misuse, abuse, negligence, accidents, repairs or alterations or lack of maintenance. This is Grizzly's sole written warranty and any and all warranties that may be implied by law, including any merchantability or fitness, for any particular purpose, are hereby limited to the duration of this written warranty. We do not warrant or represent that the merchandise complies with the provisions of any law or acts unless the manufacturer so warrants. In no event shall Grizzly's liability under this warranty exceed the purchase price paid for the product and any legal actions brought against Grizzly shall be tried in the State of Washington, County of Whatcom.

We shall in no event be liable for death, injuries to persons or property or for incidental, contingent, special, or consequential damages arising from the use of our products.

To take advantage of this warranty, contact us by mail or phone and give us all the details. We will then issue you a "Return Number," which must be clearly posted on the outside as well as the inside of the carton. We will not accept any item back without this number. Proof of purchase must accompany the merchandise.

The manufacturers reserve the right to change specifications at any time because they constantly strive to achieve better quality equipment. We make every effort to ensure that our products meet high quality and durability standards and we hope you never need to use this warranty.

Please feel free to write or call us if you have any questions about the machine or the manual.

Thank you again for your business and continued support. We hope to serve you again soon.

# *grizzly.com*

**TOOL WEBSITE**

Buy Direct and Save with Grizzly® – Trusted, Proven and a Great Value!

*Visit Our Website Today And Discover  
Why Grizzly® Is The Industry Leader!*

- SECURE ORDERING
- ORDERS SHIPPED WITHIN 24 HOURS
- E-MAIL RESPONSE WITHIN ONE HOUR

-OR-

Call Today For A **FREE**  
Full Color Catalog

**1-800-523-4777**

